

# EF600

HIGH PERFORMANCE STRUCTURAL PURE EPOXY

CERTIFICATION

TECHNICAL DATA



**NSF/ANSI 61**  
Certified NSF/ANSI 61



**ICC-ESR 4732**  
ICC-ESR Evaluated



**FOR INSTALL SUPPORT**  
[sales@allfasteners.com](mailto:sales@allfasteners.com)



**FOR SPECIFICATION SUPPORT**  
[certs@allfasteners.com](mailto:certs@allfasteners.com)



**FOR CUSTOMER SUPPORT**  
888.859.6060





**EF600**  
HIGH PERFORMANCE STRUCTURAL PURE EPOXY



ICC ESR-4732

**EF600** is a code compliant, two-component, 1:1 mix ratio by volume, high performance epoxy anchoring system approved for use in cartridges and in bulk with threaded rod and reinforcing bar for cracked and uncracked concrete conditions, and internally threaded inserts in uncracked concrete in accordance with ACI 355.4 and ICC-ES AC308.



ICC-ESR 4732 Certified NSF/ANSI 61 NY DOT Approved NJ DOT Approved OH DOT Approved VA DOT Approved



IBC  
Compliant

IRC  
Compliant

NYC SCA Approved



## ADVANTAGES & FEATURES

- Evaluation report for cracked and uncracked concrete.
- Assessed for resisting short term loading conditions up to 205 °F (96 °C).
- Suitable for core drilled installations in dry or water saturated concrete.
- UL Certified – Drinking Water System Components to NSF/ANSI 61 & Lead Free to NSF/ANSI 372.

## STANDARDS & APPROVALS

- IBC & IRC 2018, 2015, 2012 & 2009
- Qualified for Seismic Activity Categories A to F
- UL Certified – Drinking Water System Components to NSF/ANSI 61 & Lead Free to NSF/ANSI 372
- Florida Building Code (FBC) Compliant: 2017 & 2014
- City of Los Angeles (LABC/LARC) Code Compliant: 2017
- Abu Dhabi International Building Code (ADIBC) Compliant: 2013
- OSHA Table 1 compliant drilling/cleaning method using Allfasteners Dustless SDS Drilling Systems
- NJDOT QPL
- NYSDOT Approval
- OH DOT Approval
- VA DOT Approval
- NYC SCA Masonry – Terra Cotta, code 04250
- NYC SCA Masonry – Exterior Cut Stone, code 04420
- NYC SCA Masonry – Cast Stone, code 04720
- NYC SCA Metals – Structural Steel, code 05120

## COLOR RATIO

Part A (Resin) White: Part B (Hardener) Dark Gray, Mixed Ratio: 1:1 by volume, Mixed Color - Gray

## STORAGE & SHELF LIFE

24 months when stored in unopened containers in dry and dark conditions. Store between 40 °F (4 °C) and 95 °F (35 °C).

## INSTALLATION & COVERAGE

Manufacturer's Printed Installation Instructions (MPII) are available in this Technical Data Sheet (TDS). Due to occasional updates and revisions, always verify that you are using the most current version of the MPII. In order to achieve maximum results, proper installation is imperative.

## CLEAN UP

Clean uncured materials from tools and equipment with mild solvents. Cured material can only be removed mechanically.



## LIMITATIONS & WARNINGS

- Do not thin with solvents, as this will prevent cure.
- For anchoring applications, concrete should be a minimum of 21 days old prior to anchor installation per ACI 355.4.
- Bulk versions of EF600 cannot be mixed by hand and must only be mixed using an automatic pro portioning plural component pump (see MPII / IC for details).

## SAFETY

Please refer to the Safety Data Sheet (SDS) for EF600. Call Allfasteners for more information 888 859 6060.

## SPECIFICATION

Anchoring adhesive shall be a two component, 1:1 ratio by volume, epoxy anchoring system supplied in premeasured cartridges or bulk. Adhesive must meet the requirements of ICC-ES AC308, ACI 355.4 and ASTM C881 specification for Type I, II, IV and V, Grade 3 Class A, B & C. Adhesive must have a compressive yield strength of 14,480 psi (99.8 MPa) at 75 °F (24 °C) after a 7 day cure per ASTM D695. Adhesive shall be EF600 from Anchors shall be installed per the Manufacturer's Printed Installation instructions (MPII) for EF600 anchoring system.

## ESR-4732 EVALUATION REPORT

### 1.0 RECOGNITION & CERTIFICATIONS

- ICC-ES ESR-4732
- IBC/IRC 2018, 2015, 2012, & 2009
- City of Los Angeles 2017
- Florida Building Code 2017 & 2014
- Abu Dhabi International Building Code 2013
- Drinking Water System Components NSF/ANSI 61 & 372
- AASHTO M235 / ASTM C881-15
- Type I, II, IV & V Grade 3 Class A, B & C
- Department of Transportation (DOT) Approved or Pending Nationwide

### 2.0 USES

#### General Uses and Applications include:

- Anchoring threaded rod and reinforcing bar (rebar) into cracked or uncracked concrete using a hammer drill
- Suitable for dry, water saturated, & water-filled conditions using threaded rod or rebar
- Vertical down, horizontal, upwardly inclined and overhead installations

#### General Material Used In:

- Terracotta
- CMU block
- Hollow core type concrete material"
- Limestone
- Brick
- Hollow Brick

**TABLE 1: EF600 ADHESIVE PACKAGING, DISPENSING TOOLS & ACCESSORIES**

<b>PACKAGING SIZE</b>	21.2 fl. oz. (627mL) Cartridge <sup>1</sup>
<b>PART #</b>	1EF600-22
<b>MIXING NOZZLE</b>	1HF20
<b>PNEUMATIC DISPENSING TOOL</b>	13CAG435
<b>PALLET QTY</b>	432

- Each cartridge is packaged with one mixing nozzle.
- For bulk dispensing pumps, contact AF for recommended manufactures



## 2.0 USES (CONTINUED)

In order to reduce the risks to respirable crystalline silica, EF600 has been tested and approved for use in conjunction with Milwaukee Tool's OSHA compliant, commercially available dust extraction products for use in combination with EF600 installations in dry and water saturated (damp) concrete (see Table 2 for details). When used in accordance with the manufacturer's instructions, and in conjunction with EF600, these Vacuum Drill Bits along with the Dust Extractor with HEPA filter as specified by Milwaukee Tool, can completely replace the traditional blow-brush-blow cleaning method used to install threaded rod (see Installation Instructions (MPII) for more detail). Important: Prior to injecting the adhesive, the hole must always be clean, either by using self-cleaning vacuum bits or by using the blow-brush-blow cleaning method with a traditional hammer drill bit and dust shroud. Only vacuuming out a hole drilled with a standard masonry bit is NOT acceptable and will yield lower performance than published for the anchoring/doweling adhesive.

## ACCESSORIES ORDERING INFORMATION

**TABLE 2: MILWAUKEE VACUUM DRILL COMPONENTS**

PART #	DRILL TYPE	DRILL BIT SIZE in.	OVERALL LENGTH in.	USABLE LENGTH in.
48-20-2102	SDS+	7/16	13	7-7/8
48-20-2106		1/2	13	7-7/8
48-20-2110		9/16	14	9-1/2
48-20-2114		5/8	14	9-1/2
48-20-2118		3/4	14	9-1/2
48-20-2152	SDS-Max	5/8	23	15-3/4
48-20-2156		3/4	23	15-3/4
48-20-2160		7/8	23	15-3/4
48-20-2164		1	25	17-1/2
48-20-2168		1-1/8	35	27
48-20-2172		1-3/8	35	27
8960-20	8 Gallon Dust Extractor Vacuum			

**TABLE 3: EF600 INSTALLATION PARAMETERS, BRUSHES & PISTON PLUGS**

THREADED ROD in.	REBAR	DRILL BIT DIAMETER in.	MAXIMUM INSTALLATION TORQUE ft.-lbs. (N-m)	BRUSH PART #	BRUSH LENGTH in.	PISTON PLUG PART #	COLOR
3/8	-	7/16	15 (20)	B716	6	PP716	Black
-	#3	1/2	-	B12		PP916	Blue
1/2	-	9/16	30 (41)	B916		PP58	Red
-	#4	5/8	-	B58		PP34	Yellow
5/8	#5	3/4	60 (82)	B34		PP78	Green
3/4	#6	7/8	105 (82)	B78		PP100	Black
7/8	#7	1	125 (170)	B100	9	PP118	Orange
1	#8	1-1/8	165 (224)	B118		PP138	Brown
1-1/4	#9	1-3/8	280 (381)	B138		PP112	Gray
-	#10	1-1/2	-	B112			



ASTM A36 GRADE 36; ASTM F1554 GRADE 36

**ACCESSORIES ORDERING INFORMATION**

**TABLE 4: ASTM A36 GRADE 36; ASTM F1554 GRADE 36**

PART NUMBER FOR STUD	DESCRIPTION DIA. X L	MAX FIXTURE THICKNESS $t_{fix}$	MINIMUM EMBEDMENT DEPTH $h_{ef,min}$	DRILL HOLE DIA. $d_o$	DRILL HOLE DEPTH	MINIMUM CONCRETE THICKNESS $h_{min}$	DESIGN CAPACITY IN 2,500 psi CRACKED CONCRETE <sup>1</sup>	
							TENSION	SHEAR
1SCMZ38418	3/8-16 x 4-1/8"	1"	2-3/8"	7/16"	2-5/8"	4"	2022 lbs.	702 lbs.
1SCMZ38518	3/8-16 x 5-1/8"	2"	2-3/8"	7/16"	2-5/8"	4"	2022 lbs.	702 lbs.
1SCMZ38638	3/8-16 x 6-3/8"	3-1/4"	2-3/8"	7/16"	2-5/8"	4"	2022 lbs.	702 lbs.
1SCMZ12612	1/2-13 x 6-1/2"	2-3/4"	2-3/4"	9/16"	3"	4"	2520 lbs.	1149 lbs.
1SCMZ58712	5/8-11 x 7-1/2"	3-1/8"	3-1/8"	3/4"	3-3/8"	4-5/8"	3052 lbs.	1941 lbs.
1SCMZ3410	3/4-10 x 10"	5"	3-1/2"	7/8"	3-3/4"	5-1/4"	3618 lbs.	2642 lbs.

**TABLE 5: ASTM A193 GRADE B7; ASTM F1554 GRADE 105**

PART NUMBER FOR STUD	DESCRIPTION DIA. X L	MAX FIXTURE THICKNESS $t_{fix}$	MINIMUM EMBEDMENT DEPTH $h_{ef,min}$	DRILL HOLE DIA. $d_o$	DRILL HOLE DEPTH	MINIMUM CONCRETE THICKNESS $h_{min}$	DESIGN CAPACITY IN 2,500 psi CRACKED CONCRETE <sup>1</sup>	
							TENSION	SHEAR
1SCMG38418	3/8-16 x 4-1/8"	1"	2-3/8"	7/16"	2-5/8"	4"	2022 lbs.	702 lbs.
1SCMG38518	3/8-16 x 5-1/8"	2"	2-3/8"	7/16"	2-5/8"	4"	2022 lbs.	702 lbs.
1SCMG38638	3/8-16 x 6-3/8"	3-1/4"	2-3/8"	7/16"	2-5/8"	4"	2022 lbs.	702 lbs.
1SCMG12612	1/2-13 x 6-1/2"	2-3/4"	2-3/4"	9/16"	3"	4"	2520 lbs.	1149 lbs.
1SCMG58712	5/8-11 x 7-1/2"	3-1/8"	3-1/8"	3/4"	3-3/8"	4-5/8"	3052 lbs.	1941 lbs.
1SCMG3410	3/4-10 x 10"	5"	3-1/2"	7/8"	3-3/4"	5-1/4"	3618 lbs.	2642 lbs.

**TABLE 6: ASTM F953 CW STAINLESS STEEL TYPE 304 & 316**

PART NUMBER FOR STUD	DESCRIPTION DIA. X L	MAX FIXTURE THICKNESS $t_{fix}$	MINIMUM EMBEDMENT DEPTH $h_{ef,min}$	DRILL HOLE DIA. $d_o$	DRILL HOLE DEPTH	MINIMUM CONCRETE THICKNESS $h_{min}$	DESIGN CAPACITY IN 2,500 psi CRACKED CONCRETE <sup>1</sup>	
							TENSION	SHEAR
1SCMS438418	3/8-16 x 4-1/8"	1"	2-3/8"	7/16"	2-5/8"	4"	2022 lbs.	702 lbs.
1SCMS438518	3/8-16 x 5-1/8"	2"	2-3/8"	7/16"	2-5/8"	4"	2022 lbs.	702 lbs.
1SCMS438638	3/8-16 x 6-3/8"	3-1/4"	2-3/8"	7/16"	2-5/8"	4"	2022 lbs.	702 lbs.
1SCMS412612	1/2-13 x 6-1/2"	2-3/4"	2-3/4"	9/16"	3"	4"	2520 lbs.	1149 lbs.
1SCMS458712	5/8-11 x 7-1/2"	3-1/8"	3-1/8"	3/4"	3-3/8"	4-5/8"	3052 lbs.	1941 lbs.
1SCMS43410	3/4-10 x 10"	5"	3-1/2"	7/8"	3-3/4"	5-1/4"	3618 lbs.	2642 lbs.



**MATERIAL SPECIFICATIONS**

**TABLE 7: EF600 PERFORMANCE TO ASTM C881-15<sup>1,2,3</sup>**

PROPERTY	CURE TIME	ASTM STANDARD	UNITS	PROPERTY				
				CLASS A	CLASS B	OPTIONAL	OPTIONAL	CLASS C
				PROPERTY	PROPERTY	PROPERTY	PROPERTY	PROPERTY
Gel Time - 60 Gram Mass	-	C881	min	14	13	10	24	24
Gel Time - 60 Gram Mass	-	C881	-	No-Sag				
Gel Time - 60 Gram Mass	7 Day	D695	psi (MPa)	12,980 (89.5)	13,280 (91.6)	14,480 (99.8)	14,500 (100.0)	13,430 (92.6)
Gel Time - 60 Gram Mass			psi (MPa)	534,900 (3,688)	506,100 (3,489)	475,900 (3,281)	599,600 (4,134)	585,600 (4,038)
Gel Time - 60 Gram Mass	2 Day	C882	psi (MPa)	2,700 (18.6)	2,770 (19.1)	2,780 (19.2)	3,150 (21.7)	2,050 (14.1)
Gel Time - 60 Gram Mass	14 Day		psi (MPa)	2,860 (19.7)	2,950 (20.3)	3,110 (21.4)	3,050 (21.0)	2,080 (14.3)
Gel Time - 60 Gram Mass			psi (MPa)	2,730 (18.8)				
Gel Time - 60 Gram Mass	7 Day	D638	psi (MPa)	6,780 (46.7)				
Gel Time - 60 Gram Mass			psi (MPa)	1.0				
Gel Time - 60 Gram Mass	14 Day	D648	°F (°C)	148 (64)				
Gel Time - 60 Gram Mass		D570	%	0.02				
Gel Time - 60 Gram Mass	-	D2566	%	0.003				

1. Product testing results based on representative lot(s). Average results will vary according to the tolerances of the given property.
2. Full cure time is listed above to obtain the given properties for each product characteristic.
3. Results may vary due to environmental factors such as temperature, moisture and type of substrate.
4. Gel time may be lower than the minimum required for ASTM C881.
5. Optional testing for ASTM C881 Grade 3.

**TABLE 8: EF600 NSF/ANSI CERTIFICATIONS<sup>1</sup>**

ANSI CERTIFICATION	DESCRIPTION	APPLICATION	WATER CONTACT TEMPERATURE	ANCHOR SIZE INSTALLED IN CONCRETE
NSF 61	Drinking Water System Components - Health Effects	Joining and Sealing Materials	Commercial Hot 180 ± 4°F (82 ± 2°C)	Threaded Rod and Rebar ≤ 1-1/4 in. Diameter
NSF 372 <sup>2</sup>	Lead Free, U.S. Safe Drinking Water Act			

1. EF600 is certified as a joining and sealing material. Mix Ratio: Part A (Resin): Part B (Hardener) = 1:1 by volume. Application method: Dispensing mixing nozzle system. Final Cure Time: 24 hours at 75 °F (24 °C).
2. EF600 is certified to NSF/ANSI 372 and conforms to the lead content requirements for “lead free” plumbing as defined Vermont state law, and the U.S. Safe Drinking Water Act.



## INSTALLATION PARAMETERS

**TABLE 9: INSTALLATION PARAMETERS OF THREADED ROD**

ANCHOR SIZE			3/8"	1/2"	5/8"	3/4"	7/8"	1"	1-1/4"
Nominal Drill Hole Diameter	$d_o$	in.	7/16	9/16	3/4	7/8	1	1-1/8	1-3/8
Torque Moment (A36/A307)	$T_{fixt,max}$	ft.lb.	10	25	50	90	125	165	280
Torque Moment (A193 B7 or F593 SS)	$T_{fixt,max}$	ft.lb.	16	33	60	105	125	165	280
Embedment Depth (Hammer Drilled)	$h_{ef,min}$	in.	2-3/8	2-3/4	3-1/8	3-1/2	3-3/4	4	5
Embedment Depth (Hammer Drilled)	$h_{ef,max}$	in.	7-1/2	10	12-1/2	15	17-1/2	20	25
Depth of Drill Hole	$h_o$	in.	$h_{ef} + 1/4$						
Minimum Edge Distance	$c_{min}$	in.	2-3/16	2-13/16	3-3/4	4-3/8	5	5-5/8	6-7/8
Minimum Spacing	$s_{min}$	in.	2-3/16	2-13/16	3-3/4	4-3/8	5	5-5/8	6-7/8
Minimum Thickness of Member	$h_{min}$	in.	$h_{ef} + 1-1/4, \geq 3.94$		$h_{ef} + 2*d_o$ , where $d_o$ is hole diameter				

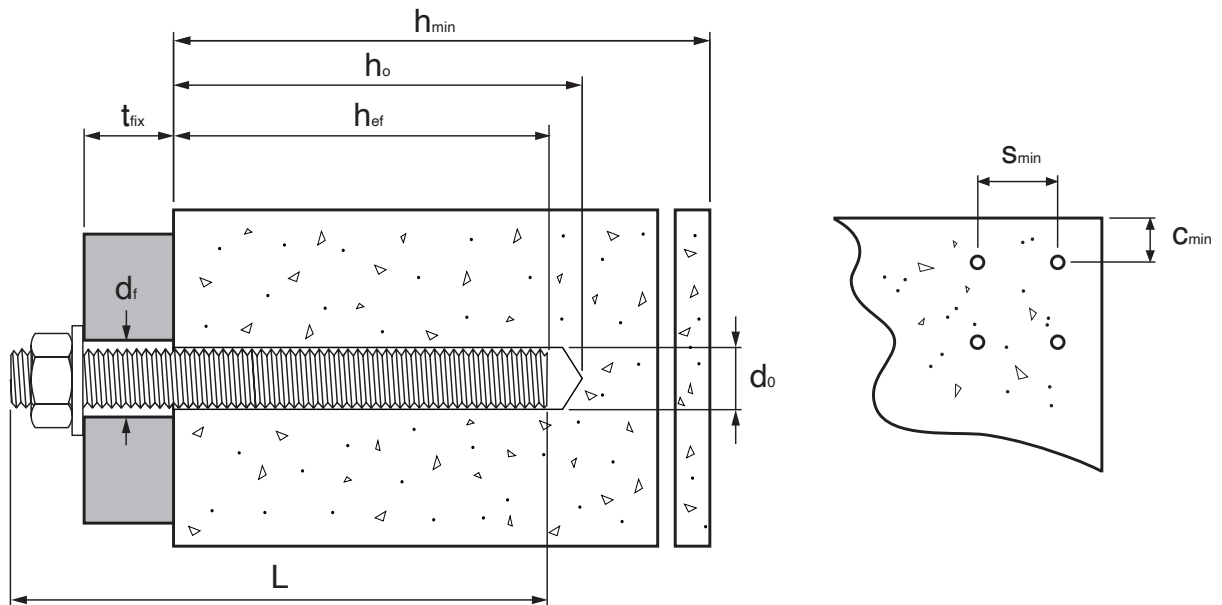

**EF600**

HIGH PERFORMANCE STRUCTURAL PURE EPOXY



ICC ESR-4732

**INSTALLATION PARAMETERS****TABLE 10: INSTALLATION PARAMETERS OF REBAR**

ANCHOR SIZE			#3	#4	#5	#6	#7	#8	#9	#10
Nominal Rebar Diameter	$d_a$	in.	0.375	0.500	0.625	0.750	0.875	1.000	1.127	1.270
Nominal Drill Hole Diameter	$d_o$	in.	1/2	5/8	3/4	7/8	1	1-1/8	1-3/8	1-1/2
Embedment Depth (Hammer Drilled)	$h_{ef,min}$	in.	2-3/8	2-3/4	3-1/8	3-1/2	3-3/4	4	4-1/2	5
Embedment Depth (Hammer Drilled)	$h_{ef,max}$	in.	7-1/2	10	12-1/2	15	17-1/2	20	22-1/2	25
Depth of Drill Hole	$h_o$	in.	$h_{ef} + 1/4''$							
Minimum Edge Distance	$c_{min}$	in.	2-3/16	2-13/16	3-3/4	4-3/8	5	5-5/8	6-1/4	6-7/8
Minimum Spacing	$s_{min}$	in.	2-3/16	2-13/16	3-3/4	4-3/8	5	5-5/8	6-1/4	6-7/8
Minimum Thickness of Member	$h_{min}$	in.	$h_{ef} + 1-1/4, \geq 3.94$			$h_{ef} + 2*d_o$ , where $d_o$ is hole diameter				

**TABLE 11: APPLICATION TIMES**

TEMP. (°F)	43°F	45°F	50°F	55°F	60°F	75°F	80°F	85°F	90°F	95°F	100°F	105°F	110°F
Working (mins.)	45	42	35	31	27	16	15	13	12	10	8	5	3
Cure (hrs.)	144	123	72	59	46	7	6	5	4	4	3	3	2



## INSTALLATION PARAMETERS

**TABLE 12: EF600 CURE SCHEDULE<sup>1,2,3</sup>**

BASE MATERIAL TEMPERATURE °F (°C)	WORKING TIME (mins.)	FULL CURE TIME (hr)
43 (6)	45	144
50 (10)	35	72
75 (24)	16	7
90 (32)	12	4
110 (43)	3	2

- Working and full cure times are approximate, may be linearly interpolated between listed temperatures and are based on cartridge/nozzle system performance.
- Application Temperature: Substrate and ambient air temperature should be between 43 -110 °F (6 - 43 °C) for applications requiring IBC/IRC code compliance.
- When ambient or base material temperature falls below 70 °F (21 °C), condition the adhesive to 70 -75 °F (21 -24 °C) prior to use.

## INSTALLATION INSTRUCTIONS (MPII)

### DRILLING & CLEANING - HAMMER DRILLED HOLES

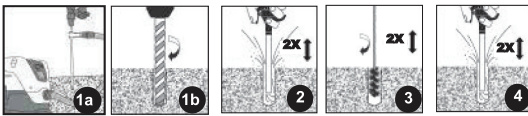

- 1a. Using a rotary hammer drill & properly connected hollow vacuum bit system, ensure vacuum is on and drill hole to specified diameter and depth. No other cleaning is necessary - go to step 8.
- 1b. If a rotary hammer drill and standard carbide bit is used, drill hole to specified diameter and depth, go to step 2. For submerged conditions, skip to step 5
2. Remove standing water and blow out hole 2 cycles (2X) using oil free compressed air.
3. Brush for 2 cycles (2X) in up/down twisting motion.
4. Repeat step 2, then go to step 8.

## REFERENCE COMMENTARY

### DRILLING & CLEANING - HAMMER DRILLED HOLES

Read and follow manufacturer’s operations manual for the selected rotary drill.

R1a. Recommended hollow vacuum bit systems for drilling dry & damp cracked and uncracked concrete. Drill bit should conform to ANSI B212.15. Once visual inspection confirms that hole is clean, proceed to step 8 for either Cartridge or Bulk Systems.

R1b. Traditional drilling method for drilling dry, water saturated and water-filled holes in cracked and uncracked concrete. Drill bit should conform to ANSI B212.15. CAUTION: Always wear appropriate personal protection equipment (PPE) for eyes, ears and skin to help avoid inhalation of dust during the drilling and cleaning process. Refer to the Safety Data Sheet (SDS) for details prior to proceeding.

R2. BLOW (2X) – BRUSH (2X) – BLOW (2X). The compressed air wand should be inserted to the bottom of the hole, have a minimum pressure of 87 psi (6 bar) and be moved in an up/down motion to remove debris.

R3. Select the correct wire brush for the hole diameter, making sure it is long enough to reach the bottom of the drilled hole, using a brush extension if necessary. CAUTION: The brush should be clean and contact the walls of the hole. If it does not, the brush is either too worn or small and should be replaced with a new brush of the correct diameter.

## INSTALLATION INSTRUCTIONS (MPII)

### SUBMERGED HOLES

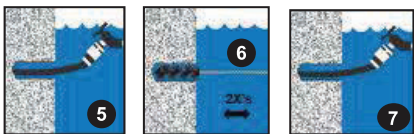

1. Using a core drill bit, drill hole to specified diameter and depth and remove the core.
2. Flush hole with pressurized water until water flowing from hole is clean and free of debris.
3. Remove standing water & blow out hole two cycles (2X) using oil free compressed air

### DRILLING & CUTTING - CORE DRILLED HOLES



1. Using a core drill bit, drill hole to specified diameter and depth and remove the core
2. Flush hole with pressurized water until water flowing from hole is clean and free of debris.
3. Remove standing water & blow out hole two cycles (2X) using oil free compressed air
5. Repeat step 3, then go to step 8.

## REFERENCE COMMENTARY

### DRILLING & CLEANING - HAMMER DRILLED HOLES

R4. After final blow step is completed, visually inspect the hole to confirm it is clean. NOTE: If installation will be delayed for any reason, cover cleaned holes to prevent contamination.

R5. For submerged (underwater) installations, FLUSH – BRUSH (2X) – FLUSH. Start at the bottom or back of the hole when flushing.

R6. Select the correct wire brush for the hole diameter, making sure it is long enough to reach the bottom of the drilled hole, using a brush extension if necessary. CAUTION: The brush should be clean and contact the walls of the hole. If it does not, the brush is either too worn or small and should be replaced with a new brush of the correct diameter.

### DRILLING & CUTTING - CORE DRILLED HOLES

Read and follow manufacturer's operations manual for the selected core drill.

R1. Once hole is cored to the proper diameter and depth, remove center core and measure to ensure that specified embedment depth can be achieved. CAUTION: Always wear appropriate personal protection equipment (PPE) for eyes, ears and skin to help avoid inhalation of dust during the drilling and cleaning process. Refer to the Safety Data Sheet (SDS) for details prior to proceeding.

R2. FLUSH – BLOW (2X) – BRUSH (2X) – BLOW (2X). Start at the bottom or back of the hole when flushing.

R3. The compressed air wand should be inserted to the bottom of the hole, have a minimum pressure of 87 psi (6 bar) and be moved in an up/down motion to remove debris.

R4. Select the correct wire brush for the hole diameter, making sure it is long enough to reach the bottom of the drilled hole, using a brush extension if necessary. CAUTION: The brush should be clean and contact the walls of the hole. If it does not, the brush is either too worn or small and should be replaced with a new brush of the correct diameter.

R5. After final blow step is completed, visually inspect the hole to confirm it is clean. NOTE: If installation will be delayed for any reason, cover cleaned holes to prevent contamination.

## INSTALLATION INSTRUCTIONS (MPII)

### DISPENSING PREPARATION - CARTRIDGE SYSTEM ONLY



8. Remove protective cap, insert cartridge into recommended dispensing tool and balance until both components come out evenly.

9. Screw on proper, non-modified mixing nozzle to cartridge.

10. Dispense and waste enough material to ensure uniform gray color before injecting into hole. For a new cartridge (or if working time has been exceeded), ensure cartridge opening is clean, install new nozzle and repeat steps 8 & 9. Go to step 13a.

### DISPENSING PREPARATION - BULK SYSTEMS ONLY



8. Pour Resin into Side A pump reservoir then close lid on Side A. Only after separately mixing Part B, pour hardener into Side B reservoir then close lid on Side B. Follow bulk pump instructions for filling the metering pump and outlet assembly, then bleed the air from the system and fill the hose and applicator.

9. Balance the bulk pump machine following instructions in the Bulk Pump Operations Manual and test to ensure that it is dispensing the material on ratio (1:1).

## REFERENCE COMMENTARY

### DISPENSING PREPARATION - CARTRIDGE SYSTEM ONLY

R8. CAUTION: Check the expiration date on the cartridge to ensure it is not expired. Do not use expired product! Before attaching mixing nozzle, balance the cartridge by dispensing a small amount of material until both components are flowing evenly. For a cleaner environment, hand mix the two components and let cure prior to disposal in accordance with local regulations.

R9. Do not modify mixing nozzle and confirm that internal mixing element is in place prior to dispensing adhesive. Take note of the air and base material temperatures and review the working/full cure time chart prior to starting the injection process.

R10. Test bead of mixed adhesive must be uniform in color and free of streaks, as adhesive must be properly mixed in order to perform as published. Dispose of the test bead according to federal, state and local regulations. CAUTION: When changing cartridges, never re-use nozzles and do not attempt to force adhesive out of a hardened mixing nozzle. Leave the mixing nozzle attached to the cartridge upon completion of work.

### DISPENSING PREPARATION - BULK SYSTEMS ONLY

The bulk pump uses a two-component delivery system whereby metering individual components and mixing of the two components are automatically controlled during dispensing through a metering manifold and disposable mixing nozzle. The bulk pump has a minimum input air pressure requirement of 80 -90 psi @ 15 CFM, supplied through a regulator which reduces the pressure in order to control the rate of dispensing. The two individual adhesive components stay separate throughout the system, until they reach the specified disposable mixing nozzle via a manifold at the end of the bulk pump wand. Under normal operation, the bulk pump must be capable of dispensing the individual components at a 1:1 mix ratio by volume with a tolerance of  $\pm 2\%$ .

R8. CAUTION: Check the expiration date on the bulk unit to ensure it is not expired. Do not use expired product! Mix Part B carefully to avoid whipping air into product.

R9. NOTE: Review Bulk Pump Operations Manual thoroughly before proceeding and follow all steps necessary for set-up and operation of the pump. Fill each reservoir (hopper) to at least one-half full. Incoming air supply pressure should be maintained at approximately 100 psi (6.9 bar).

R10. Be sure to establish proper flow of both materials at the applicator tip prior to attaching mixing nozzle. A ratio check should always be performed before installation begins to confirm that equal volumes of Part A and Part B are being dispensed. This check must be completed prior to attaching the mixing nozzle.

## INSTALLATION INSTRUCTIONS (MPII)

### INSTALLATION & CURING

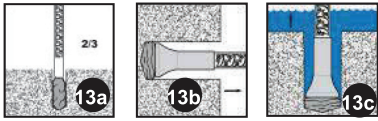

13a. Fill hole 2/3 full with adhesive starting at the bottom and withdraw as hole fills, using an extension tube as needed. Only fill hole 1/2 full when installing inserts.

13b. Use piston plugs for overhead and vertically inclined installations.

13c. If injecting in a water-filled hole, or underwater in a submerged condition, fill hole completely with adhesive as described in 13b.



14a. Fully insert clean threaded rod or rebar with slow turning motion to the bottom of the hole. For internally threaded inserts, thread a bolt into the insert and press it into the hole, finishing with hammer strikes until it is flush with the surface of the concrete.

14b. For horizontal, inclined or overhead installations, use wedges to support the anchor while curing.

15. Do not disturb, torque or apply load until full cure time has passed.

## REFERENCE COMMENTARY

### INSTALLATION & CURING

NOTE: Building Code Requirements for Structural Concrete (ACI 318-14) requires the Installer to be certified where adhesive anchors are to be installed in horizontal to vertically inclined (overhead) installations. The engineering drawings must be followed. For all applications not covered by this document, or for all installation questions, please contact Allfasteners

R13a. Be careful not to withdraw the mixing nozzle too quickly as this may trap air in the adhesive. Extension tubing can be connected as needed onto the outside of the tip of both the small mixing nozzle (T12) and the large mixing nozzle (T34HF).

NOTE: When using a pneumatic dispensing tool, ensure that pressure is set at 90 psi (6.2 bar) maximum.

R13b. Select the proper piston plug for the drill hole diameter. The piston plug fits directly onto the tip of both the small and large mixing nozzle. Extension tubing may also be used if needed in order to reach the bottom of the drill hole.

R13c. Be careful not to withdraw the mixing nozzle assembly too quickly as this may trap water in the adhesive. The piston plug should push itself out of the hole from the pressure of the injected adhesive.

R14a. Prior to inserting the threaded rod or rebar into the hole, make sure it is straight, clean and free of oil/dirt and that the necessary embedment depth is marked on the anchor element. Insert the anchor elements into the hole while turning 1 - 2 rotations prior to the anchor reaching the bottom of the hole. Excess adhesive should be visible on all sides of the fully installed rod or rebar, but may not be visible on all sides of the insert. **CAUTION:** Use extra care with deep embedment or high temperature installations to ensure that the working time has not elapsed prior to the anchor being fully installed. Adjustments to the anchor alignment may only performed during the published working time for a given temperature.

R14b. For overhead, horizontal and inclined (between horizontal and overhead), wedges should be used to support the anchor while the adhesive is curing. Take appropriate steps to protect the exposed threads of the anchor element from uncured adhesive until after the full cure time has elapsed.

R15. The amount of time needed to reach full cure is base material dependent. Refer to the chart for appropriate full cure time for a given temperature.



## TECHNICAL DATA

EF600 has been tested and assessed by an accredited independent testing laboratory in accordance with ICC -ES AC308, ACI 355.4 and ASTM E488 for use in cracked and uncracked, normal and lightweight concrete, for loading conditions including seismic and wind, for structural design to ACI 318-14 Chapter 17 (ACI 318-11/08 Appendix D) and is approved per ICC-ES ESR-4732. The design process and parameters for EF600 are shown in Figure 1, Tables 8 - 19 for Strength Design and Tables 20 - 23 for Allowable Stress Design.

**TABLE 13: EF600 DESIGN STRENGTH INDEX**

DESIGN STRENGTH		DRILLING METHOD	THREADED ROD	REBAR	INTERNAL THREADED INSERT
Steel Strength	$N_{sa}, V_{sa}$	-	8	13	17
Concrete Breakout	$N_{cb}, V_{cb}, V_{cp}$	-	9	14	18
Strength Design Bond Strength (SD)	Cracked Concrete	Hammer Drilled	10	15	-
	Uncracked Concrete		10	15	19
	Cracked Concrete	Vacuum Bit Drilled	11	-	-
	Uncracked Concrete		11	-	-
	Uncracked Concrete	Core Drilled	12	16	-
Allowable Stress Design (ASD)	Allowable Tension Load	Hammer Drilled	20	22	-
	Allowable Shear Load		21	23	-



**TECHNICAL DATA**

**TABLE 14: EF600 STEEL DESIGN INFORMATION FOR THREADED<sup>1</sup> ROD**

DESIGN STRENGTH			SYMBOL	UNIT	THREADED ROD						
					3/8"	1/2"	5/8"	3/4"	7/8"	1"	1-1/4"
Nominal Anchor Diameter			d	in. (mm)	0.375 (9.5)	0.500 (12.7)	0.625 (15.9)	0.750 (19.1)	0.875 (22.2)	1.000 (25.4)	1.250 (31.8)
Threaded Rod Cross-Sectional Area <sup>2</sup>			A <sub>se</sub>	in. <sup>2</sup> (mm <sup>2</sup> )	0.078 (50)	0.142 (92)	0.226 (146)	0.335 (216)	0.462 (298)	0.606 (391)	0.969 (625)
Carbon Steel	ASTM A36 Grade 36	Nominal Strength as Governed by Steel Strength	N <sub>sa</sub>	lb. (kN)	4,495 (20.0)	8,230 (36.6)	13,110 (58.3)	19,370 (86.2)	26,795 (119.2)	35,150 (156.4)	56,200 (250.0)
			V <sub>sa</sub>	lb. (kN)	2,695 (12.0)	4,940 (22.0)	7,865 (35.0)	11,625 (51.7)	16,080 (71.5)	21,090 (93.8)	33,720 (150.0)
		Reduction Factor for Seismic Shear	aV <sub>seis</sub>	-	0.83	0.78	0.74	0.70	0.69	0.67	0.65
		Strength Reduction Factor for Tension <sup>3</sup>	Φ	-	0.75						
		Strength Reduction Factor for Shear <sup>3</sup>	Φ	-	0.65						
	ASTM A193 B7 ASTM F1554 Grade 105	Nominal Strength as Governed by Steel Strength	N <sub>sa</sub>	lb. (kN)	9,685 (43.1)	17,735 (78.9)	28,250 (125.7)	41,750 (185.7)	57,750 (256.9)	75,750 (337.0)	121,125 (538.8)
			V <sub>sa</sub>	lb. (kN)	5,815 (25.9)	10,645 (47.4)	16,950 (75.4)	25,050 (111.4)	34,650 (154.1)	45,450 (202.2)	72,675 (323.3)
		Reduction Factor for Seismic Shear	aV <sub>seis</sub>	-	0.60	0.58	0.57	0.55	0.53	0.50	0.46
		Strength Reduction Factor for Tension <sup>4</sup>	Φ	-	0.75						
		Strength Reduction Factor for Shear <sup>4</sup>	Φ	-	0.65						
Stainless Steel	ASTM F593 CW Stainless Types 304 & 316	Nominal Strength as Governed by Steel Strength	N <sub>sa</sub>	lb. (kN)	7,750 (34.5)	14,190 (63.1)	22,600 (100.5)	28,390 (126.0)	39,270 (174.7)	51,510 (229.1)	82,365 (366.4)
			V <sub>sa</sub>	lb. (kN)	4,650 (20.7)	8,515 (37.9)	13,560 (60.3)	17,035 (75.8)	23,560 (104.8)	30,905 (137.5)	49,420 (219.8)
		Reduction Factor for Seismic Shear	aV <sub>seis</sub>	-	0.65	0.62	0.60	0.58	0.57	0.55	0.53
		Strength Reduction Factor for Tension <sup>4</sup>	Φ	-	0.65						
		Strength Reduction Factor for Shear <sup>4</sup>	Φ	-	0.60						

For SI: 1 inch = 25.4 mm, 1lbf = 4.448 N, 1 psi = 0.006897 MPa

For pound-inch units: 1 mm = 0.03937 inch, 1 N = 0.2248 lbf, 1MPa = 145.0 psi

- Values provided for post-installed anchors with category as determined from ACI 355.4 given for Condition B. Condition B applies without supplementary reinforcement or where pullout (bond) or pryout govern, as set forth in ACI 318-14 17.3.3 or ACI 318-11 D.4.3, as applicable, while condition A requires supplemental reinforcement. Values are for use with the load combinations Section 1605.2 of the IBC, ACI 318-14 5.3 or ACI 318-11 Section 9.2, as applicable, as set forth in ACI 318-11 D.4.3. If the load combinations of ACI 318-11 Appendix C are used, the appropriate value of must be determined in accordance with ACI 318-11 D.4.4.



**TECHNICAL DATA**

**TABLE 15: EF600 CONCRETE BREAKOUT<sup>1</sup> DESIGN INFORMATION FOR THREADED ROD**

DESIGN STRENGTH	SYMBOL	UNIT	THREADED ROD						
			3/8"	1/2"	5/8"	3/4"	7/8"	1"	1-1/4"
Minimum Embedment Depth	$h_{er,min}$	in. (mm)	2-3/8 (60)	2-3/4 (70)	3-1/8 (79)	3-1/2 (89)	3-1/4 (95)	4 (102)	5 (127)
Maximum Embedment Depth	$h_{er,max}$	in. (mm)	7-1/2 (191)	10 (254)	12-1/2 (318)	15 (381)	17-1/2 (445)	20 (508)	25 (635)
Effectiveness Factor for Cracked Concrete	$k_{c,cr}$	- SI	17 (7.1)						
Effectiveness Factor for Uncracked Concrete	$k_{c,uncr}$	- SI	24 (10)						
Minimum Spacing Distance	$s_{min}$	in. (mm)	$s_{min} = c_{min}$						
Minimum Edge Distance	$c_{min}$	in. (mm)	2-3/16 (56)	2-13/16 (71)	3-3/4 (95)	4-3/8 (111)	5 (127)	5-5/8 (143)	6-7/8 (175)
Minimum Concrete Thickness	$h_{min}$	in. (mm)	hef + 1.25, [ $\geq 3.937$ ] (hef + 30, [ $\geq 100$ ])		$h_{ef} + 2d_0$ where $d_0$ is the hole diameter				
Critical Edge Distance (Uncracked Concrete Only)	$c_{ac}$	in.	$C_{ac} = h_{ef} \cdot \left( \frac{\min(\tau_{k,uncr}; \tau_{k,max})}{1160} \right)^{0.4} \cdot \max \left[ \left( 3.1 - 0.7 \frac{h}{h_{ef}} \right); 1.4 \right]$						
		mm	$C_{ac} = h_{ef} \cdot \left( \frac{\min(\tau_{k,uncr}; \tau_{k,max})}{8} \right)^{0.4} \cdot \max \left[ \left( 3.1 - 0.7 \frac{h}{h_{ef}} \right); 1.4 \right]$						
Strength Reduction Factor for Tension, Concrete Failure Mode, Condition B <sup>1</sup>	$\Phi$	-	0.65						
Strength Reduction Factor for Shear, Concrete Failure Mode, Condition B <sup>1</sup>	$\Phi$	-	0.70						

For SI: 1 inch = 25.4 mm, 1lbf = 4.448 N, 1 psi = 0.006897 MPa

For pound-inch units: 1 mm = 0.03937 inch, 1 N = 0.2248 lbf, 1MPa = 145.0 psi

1. Values provided for post-installed anchors with category as determined from ACI 355.4 given for Condition B. Condition B applies without supplementary reinforcement or where pullout (bond) or pryout govern, as set forth in ACI 318-14 17.3.3 or ACI 318-11 D.4.3, as applicable, while condition A requires supplemental reinforcement. Values are for use with the load combinations Section 1605.2 of the IBC, ACI 318-14 5.3 or ACI 318-11 Section 9.2, as applicable, as set forth in ACI 318-11 D.4.3. If the load combinations of ACI 318-11 Appendix C are used, the appropriate value of must be determined in accordance with ACI 318-11 D.4.4.



**TECHNICAL DATA**

**TABLE 16: EF600 BOND STRENGTH DESIGN INFORMATION FOR THREADED ROD IN HOLES DRILLED WITH A HAMMER DRILL & CARBIDE BIT - MAXIMUM LONG TERM SERVICE TEMPERATURE 110°F (43°C)<sup>1,2,3,4</sup>**

DESIGN INFORMATION			SYMBOL	UNIT	THREADED ROD						
					3/8"	1/2"	5/8"	3/4"	7/8"	1"	1-1/4"
Minimum Embedment Depth			$h_{ef,min}$	in. (mm)	2-3/8 (60)	2-3/4 (70)	3-1/8 (79)	3-1/2 (89)	3-1/4 (95)	4 (102)	5 (127)
Maximum Embedment Depth			$h_{ef,max}$	in. (mm)	7-1/2 (191)	10 (254)	12-1/2 (318)	15 (381)	17-1/2 (445)	20 (508)	25 (635)
Maximum Short Term Temp. 150°F (66°C)	Cracked Concrete Characteristic Bond Strength	With Sustained Load	$T_{k,cr}$	psi (MPa)	1,415 (9.8)	1,250 (8.6)	1,415 (9.8)	1,415 (9.8)	1,200 (8.3)	1,330 (9.2)	1,275 (8.8)
		No Sustained Load		psi (MPa)	1,625 (11.2)	1,435 (9.9)	1,625 (11.2)	1,625 (11.2)	1,380 (9.5)	1,525 (10.5)	1,465 (10.1)
	Uncracked Concrete Characteristic Bond Strength	With Sustained Load	$T_{k,uncr}$	psi (MPa)	2,495 (17.2)	2,400 (16.5)	2,300 (15.9)	2,205 (15.2)	2,105 (14.5)	2,010 (13.9)	1,810 (12.5)
		No Sustained Load		psi (MPa)	2,870 (19.8)	2,755 (19.0)	2,640 (18.2)	2,530 (17.4)	2,415 (16.7)	2,305 (15.9)	2,080 (14.3)
Maximum Short Term Temp. 180°F (82°C)	Cracked Concrete Characteristic Bond Strength	With Sustained Load	$T_{k,cr}$	psi (MPa)	1,245 (8.6)	1,100 (7.6)	1,245 (8.6)	1,245 (8.6)	1,060 (7.3)	1,165 (8.0)	1,125 (7.8)
		No Sustained Load		psi (MPa)	1,430 (9.9)	1,265 (8.7)	1,430 (9.9)	1,430 (9.9)	1,215 (8.4)	1,340 (9.2)	1,290 (8.9)
	Uncracked Concrete Characteristic Bond Strength	With Sustained Load	$T_{k,uncr}$	psi (MPa)	2,200 (15.2)	2,110 (14.5)	2,025 (14.0)	1,940 (13.4)	1,855 (12.8)	1,770 (12.2)	1,595 (11.0)
		No Sustained Load		psi (MPa)	2,525 (17.4)	2,425 (16.7)	2,325 (16.0)	2,225 (15.3)	2,130 (14.7)	2,030 (14.0)	1,830 (12.6)
Maximum Short Term Temp. 205°F (96°C)	Cracked Concrete Characteristic Bond Strength	With Sustained Load	$T_{k,cr}$	psi (MPa)	530 (3.7)	470 (3.2)	530 (3.7)	530 (3.7)	455 (3.1)	495 (3.4)	480 (3.3)
		No Sustained Load		psi (MPa)	610 (4.2)	540 (3.7)	610 (4.2)	610 (4.2)	420 (2.9)	570 (3.9)	550 (3.8)
	Uncracked Concrete Characteristic Bond Strength	With Sustained Load	$T_{k,uncr}$	psi (MPa)	935 (6.4)	900 (6.2)	850 (5.9)	830 (5.7)	790 (5.4)	755 (5.2)	680 (4.7)
		No Sustained Load		psi (MPa)	1,075 (7.4)	1,035 (7.1)	980 (6.8)	950 (6.6)	905 (6.2)	865 (6.0)	780 (5.4)

CONTINUES ON NEXT PAGE...



**TECHNICAL DATA**

**TABLE 16: EF600 BOND STRENGTH DESIGN INFORMATION FOR THREADED ROD IN HOLES DRILLED WITH A HAMMER DRILL & CARBIDE BIT - MAXIMUM LONG TERM SERVICE TEMPERATURE 110°F (43°C)<sup>1,2,3,4</sup>**

DESIGN INFORMATION			SYMBOL	UNIT	THREADED ROD						
					3/8"	1/2"	5/8"	3/4"	7/8"	1"	1-1/4"
Reduction Factor for Seismic Tension <sup>5</sup>			aN <sub>seis</sub>	-	1.00			0.77	1.00	0.97	0.96
Continuous Inspection	Strength Reduction Factors for Permissible Installation Conditions <sup>6,7,8</sup>	Dry Concrete	Φ <sub>d</sub>	-	0.65						
		Water Saturated Concrete	Φ <sub>ws</sub>	-	0.65		0.55				
		Water Filled Holes in Concrete	Φ <sub>wf</sub>	-	0.55					0.45	
			K <sub>wf</sub>	-	1.00					0.96	0.88
		Underwater Holes In Concrete	Φ <sub>uw</sub>	-	0.65						
Periodic Inspection	Strength Reduction Factors for Permissible Installation Conditions <sup>6,7,8</sup>	Dry Concrete	Φ <sub>d</sub>	-	0.65						
		Water Saturated Concrete	Φ <sub>ws</sub>	-	0.55		0.45				
		Water Filled Holes in Concrete	Φ <sub>wf</sub>	-	0.45						
			K <sub>wf</sub>	-	1.00					0.92	0.75
		Underwater Holes In Concrete	Φ <sub>uw</sub>	-	0.55						

For SI: 1 inch = 25.4 mm, 1 lbf = 4.448 N, 1 psi = 0.006897 MPa

For pound-inch units: 1 mm = 0.03937 inch, 1 N = 0.2248 lbf, 1MPa = 145.0 psi

1. Characteristic bond strength values correspond to concrete compressive strength f<sub>c</sub> = 2,500 psi (17.2 MPa). For uncracked concrete compressive strength f<sub>c</sub> between 2,500 psi (17.2 MPa) and 8,000 psi (55.2 MPa), the tabulated characteristic bond strength may be increased by a factor of (f<sub>c</sub> / 2,500)0.1 (for SI: (f<sub>c</sub> / 17.2)0.1). For cracked concrete, no increase in bond strength is permitted.
2. Lightweight concrete may be used by applying a reduction factor as given in ACI 318-14 17.2.6 or ACI 318-11 Appendix D section D3.6 as applicable.
3. Short term elevated concrete temperatures are those that occur over brief intervals, e.g., as a results of diurnal cycling. Long term concrete temperatures are roughly constant over significant periods of time.
4. Characteristic bond strength values are for sustained loads (when noted), including dead and live loads.
5. For structures in regions assigned to Seismic Design Category C, D, E, or F, the bond strength values shall be multiplied by η<sub>seis</sub>.
6. The tabulated value of Φ applies when load combinations of Section 1605.2 of the IBC or ACI 318-14 5.3 (ACI 318-11 9.2), are used in accordance with ACI 318-14 17.3.3 (ACI 318-11 D.4.3).  
If the load combinations of ACI 318-11 Appendix C are used, the appropriate value of shall be determined in accordance with ACI 318 D.4.4.
7. The values of Φ correspond to Condition B as described in ACI 318-14 17.3.3 (ACI 318-11 D.4.3) for post-installed anchors designed using the load combinations of IBC Section 1605.2. If the load combinations in ACI 318-11 Appendix C are used, the corresponding value of shall be determined.
8. The values of Φ correspond to the anchor category as set forth in ACI 318-14 17.3.3 (ACI 318-11 D.4.3). The factor of 0.65 represents a Category 1, 0.55 a Category 2 and 0.45 a Category 3.



**TECHNICAL DATA**

**TABLE 17: EF600 BOND STRENGTH DESIGN INFORMATION FOR THREADED ROD IN MILWAUKEE VACUUM BIT DRILLED HOLES - MAXIMUM LONG TERM SERVICE TEMPERATURE 110°F (43°C)<sup>1,2,3,4</sup>**

DESIGN INFORMATION			SYMBOL	UNIT	THREADED ROD				
					5/8"	3/4"	7/8"	1"	1-1/4"
Minimum Embedment Depth			$h_{er,min}$	in. (mm)	3-1/8 (79)	3-1/2 (89)	3-1/4 (95)	4 (102)	5 (127)
Maximum Embedment Depth			$h_{er,max}$	in. (mm)	12-1/2 (318)	15 (381)	17-1/2 (445)	20 (508)	25 (635)
Maximum Short Term Temp. 150°F (66°C)	Cracked Concrete Characteristic Bond Strength	With Sustained Load	$T_{k,cr}$	psi (MPa)	1,175 (8.1)	1,005 (6.9)	1,035 (7.1)	1,185 (8.2)	1,140 (7.9)
		No Sustained Load		psi (MPa)	1,350 (9.3)	1,155 (8.0)	1,185 (8.2)	1,360 (9.4)	1,310 (9.0)
	Uncracked Concrete Characteristic Bond Strength	With Sustained Load	$T_{k,uncr}$	psi (MPa)	2,105 (14.5)	2,030 (14.0)	1,955 (13.5)	1,880 (13.0)	1,730 (11.9)
		No Sustained Load		psi (MPa)	2,415 (7.1)	2,330 (16.1)	2,245 (15.5)	2,160 (14.9)	1,985 (13.7)
Maximum Short Term Temp. 180°F (82°C)	Cracked Concrete Characteristic Bond Strength	With Sustained Load	$T_{k,cr}$	psi (MPa)	1,035 (7.1)	885 (6.1)	910 (6.3)	1,045 (7.2)	1,005 (6.9)
		No Sustained Load		psi (MPa)	1,190 (8.2)	1,015 (7.0)	1,045 (7.2)	1,200 (8.3)	1,155 (8.0)
	Uncracked Concrete Characteristic Bond Strength	With Sustained Load	$T_{k,uncr}$	psi (MPa)	1,850 (12.8)	1,785 (12.3)	1,720 (11.9)	1,655 (11.4)	1,525 (10.5)
		No Sustained Load		psi (MPa)	2,125 (14.7)	2,050 (14.1)	1,975 (13.6)	1,900 (13.1)	1,750 (12.1)
Maximum Short Term Temp. 205°F (96°C)	Cracked Concrete Characteristic Bond Strength	With Sustained Load	$T_{k,cr}$	psi (MPa)	440 (3.0)	375 (2.6)	385 (2.7)	445 (3.1)	430 (3.0)
		No Sustained Load		psi (MPa)	505 (3.5)	435 (3.0)	445 (3.1)	510 (3.5)	490 (7.9)
	Uncracked Concrete Characteristic Bond Strength	With Sustained Load	$T_{k,uncr}$	psi (MPa)	790 (5.4)	760 (5.2)	735 (5.1)	705 (4.9)	650 (4.5)
		No Sustained Load		psi (MPa)	905 (6.2)	875 (6.0)	840 (5.8)	810 (5.6)	745 (5.1)
Reduction Factor for Seismic Tension <sup>5</sup>			$aN_{,seis}$	-	1.00	0.77	1.00	0.97	0.96
Continuous Inspection	Strength Reduction Factors for Permissible Installation Conditions <sup>6,7,8</sup>	Dry Concrete	$\Phi_d$	-	0.65				
		Wet Saturated Concrete	$\Phi_{ws}$	-	0.45	0.55	0.65		
			$K_{ws}$	-	1.00				
Periodic Inspection	Strength Reduction Factors for Permissible Installation Conditions <sup>6,7,8</sup>	Dry Concrete	$\Phi_d$	-	0.65				
		Wet Saturated Concrete	$\Phi_{ws}$	-	0.45	0.55			
			$K_{ws}$	-	0.89	0.95	1.00		

TABLE NOTES ON NEXT PAGE...

**EF600**

HIGH PERFORMANCE STRUCTURAL PURE EPOXY



ICC ESR-4732

**TECHNICAL DATA**

For SI: 1 inch = 25.4 mm, 1 lbf = 4.448 N, 1 psi = 0.006897 MPa

For pound-inch units: 1 mm = 0.03937 inch, 1 N = 0.2248 lbf, 1MPa = 145.0 psi

1. Characteristic bond strength values correspond to concrete compressive strength  $f'_c = 2,500$  psi (17.2 MPa). For uncracked concrete compressive strength  $f'_c$  between 2,500 psi (17.2 MPa) and 8,000 psi (55.2 MPa), the tabulated characteristic bond strength may be increased by a factor of  $(f'_c / 2,500)^{0.1}$  (for SI:  $(f'_c / 17.2)^{0.1}$ ). For cracked concrete, no increase in bond strength is permitted.
2. Lightweight concrete may be used by applying a reduction factor as given in ACI 318-14 17.2.6 or ACI 318-11 Appendix D section D3.6 as applicable.
3. Short term elevated concrete temperatures are those that occur over brief intervals, e.g., as a results of diurnal cycling. Long term concrete temperatures are roughly constant over significant periods of time.
4. Characteristic bond strength values are for sustained loads (when noted), including dead and live loads.
5. For structures in regions assigned to Seismic Design Category C, D, E, or F, the bond strength values shall be multiplied by  $\psi_{n,seis}$ .
6. The tabulated value of  $\phi$  applies when load combinations of Section 1605.2 of the IBC or ACI 318-14 5.3 (ACI 318-11 9.2), are used in accordance with ACI 318-14 17.3.3 (ACI 318-11 D.4.3). If the load combinations of ACI 318-11 Appendix C are used, the appropriate value of  $\phi$  shall be determined in accordance with ACI 318 D.4.4.
7. The values of  $\phi$  correspond to Condition B as described in ACI 318-14 17.3.3 (ACI 318-11 D.4.3) for post-installed anchors designed using the load combinations of IBC Section 1605.2. If the load combinations in ACI 318-11 Appendix C are used, the corresponding value of  $\phi$  shall be determined.
8. The values of  $\phi$  correspond to the anchor category as set forth in ACI 318-14 17.3.3 (ACI 318-11 D.4.3). The factor of 0.65 represents a Category 1, 0.55 a Category 2 and 0.45 a Category 3.



**TECHNICAL DATA**

**TABLE 18: EF600 BOND STRENGTH DESIGN INFORMATION FOR THREADED ROD IN CORE DRILLED HOLES - MAXIMUM LONG TERM SERVICE TEMPERATURE 110°F (43°C)<sup>1,2,3,4</sup>**

DESIGN INFORMATION			SYMBOL	UNIT	THREADED ROD					
					1/2"	5/8"	3/4"	7/8"	1"	1-1/4"
Minimum Embedment Depth			$h_{er,min}$	in. (mm)	2-3/4 (70)	3-1/8 (79)	3-1/2 (89)	3-1/4 (95)	4 (102)	5 (127)
Maximum Embedment Depth			$h_{er,max}$	in. (mm)	10 (254)	12-1/2 (318)	15 (381)	17-1/2 (445)	20 (508)	25 (635)
Maximum Short Term Temp. 150°F (66°C)	Uncracked Concrete Characteristic Bond Strength	With Sustained Load	$T_{k,uncr}$	psi (MPa)	995 (6.9)					
		No Sustained Load		psi (MPa)	1,145 (7.9)					
Maximum Short Term Temp. 180°F (82°C)	Uncracked Concrete Characteristic Bond Strength	With Sustained Load	$T_{k,uncr}$	psi (MPa)	880 (6.1)					
		No Sustained Load		psi (MPa)	1,010 (7.0)					
Continuous Inspection	Strength Reduction Factors for Permissible Installation Conditions <sup>6,7,8</sup>	Dry Concrete	$\phi_d$	-	0.65					
		Wet Saturated Concrete	$\phi_{ws}$	-	0.65					
Periodic Inspection	Strength Reduction Factors for Permissible Installation Conditions <sup>6,7,8</sup>	Dry Concrete	$\phi_d$	-	0.65					
		Wet Saturated Concrete	$\phi_{ws}$	-	0.55					

For SI: 1 inch = 25.4 mm, 1 lbf = 4.448 N, 1 psi = 0.006897 MPa

For pound-inch units: 1 mm = 0.03937 inch, 1 N = 0.2248 lbf, 1MPa = 145.0 psi

1. Characteristic bond strength values correspond to concrete compressive strength  $f'c = 2,500$  psi (17.2 MPa). For uncracked concrete compressive strength  $f'c$  between 2,500 psi (17.2 MPa) and 8,000 psi (55.2 MPa), the tabulated characteristic bond strength may be increased by a factor of  $(f'c / 2,500)0.1$  (for SI:  $(f'c / 17.2)0.1$ ). For cracked concrete, no increase in bond strength is permitted.
2. Lightweight concrete may be used by applying a reduction factor as given in ACI 318-14 17.2.6 or ACI 318-11 Appendix D section D3.6 as applicable.
3. Short term elevated concrete temperatures are those that occur over brief intervals, e.g., as a results of diurnal cycling. Long term concrete temperatures are roughly constant over significant periods of time.
4. Characteristic bond strength values are for sustained loads (when noted), including dead and live loads.
5. K factor not listed for conditions where  $K = 1.0$ .
6. The tabulated value of  $\phi$  applies when load combinations of Section 1605.2 of the IBC or ACI 318-14 5.3 (ACI 318-11 9.2), are used in accordance with ACI 318-14 17.3.3 (ACI 318-11 D.4.3). If the load combinations of ACI 318-11 Appendix C are used, the appropriate value of  $\phi$  shall be determined in accordance with ACI 318 D.4.4.
7. The values of  $\phi$  correspond to Condition B as described in ACI 318-14 17.3.3 (ACI 318-11 D.4.3) for post-installed anchors designed using the load combinations of IBC Section 1605.2. If the load combinations in ACI 318-11 Appendix C are used, the corresponding value of  $\phi$  shall be determined.
8. The values of  $\phi$  correspond to the anchor category as set forth in ACI 318-14 17.3.3 (ACI 318-11 D.4.3). The factor of 0.65 represents a Category 1, 0.55 a Category 2 and 0.45 a Category 3.



**TECHNICAL DATA**

**TABLE 19: EF600 STEEL DESIGN INFORMATION FOR REBAR<sup>1</sup>**

DESIGN INFORMATION		SYMBOL	UNIT	REBAR							
				#3	#4	#5	#6	#7	#8	#9	#10
Nominal Anchor Diameter		$d_a$	in. (mm)	0.375 (9.5)	0.500 (12.7)	0.625 (15.9)	0.750 (19.1)	0.875 (22.2)	1.000 (25.4)	1.125 (28.6)	1.250 (31.8)
Rebar Cross-Sectional Area <sup>2</sup>		$A_{se}$	in. <sup>2</sup> (mm <sup>2</sup> )	0.110 (71)	0.200 (129)	0.310 (200)	0.440 (284)	0.600 (387)	0.790 (510)	1.000 (645)	1,270 (819)
ASTM A615 Grade 40	Nominal Strength as Governed by Steel Strength	$N_{sa}$	lb. (kN)	6,600 (29.4)	12,000 (53.4)	18,600 (82.7)	26,400 (117.4)	Grade 40 Reinforcing Bars Are Only Available in Sizes # to #6 per ASTM A615			
		$V_{sa}$	lb. (kN)	3,960 (17.6)	7,200 (32.0)	11,160 (49.6)	15,840 (70.5)				
	Reduction Factor for Seismic Shear	$aV_{,seis}$	-	0.70	0.74	0.78	0.82				
	Strength Reduction Factor for Tension <sup>3</sup>	$\phi$	-	0.75							
	Strength Reduction Factor for Shear <sup>3</sup>	$\phi$	-	0.65							
ASTM A706 Grade 60	Nominal Strength as Governed by Steel Strength	$N_{sa}$	lb. (kN)	8,800 (39.1)	16,000 (71.2)	24,800 (110.3)	35,200 (156.6)	48,000 (213.5)	63,200 (281.1)	80,000 (355.9)	101,600 (451.9)
		$V_{sa}$	lb. (kN)	5,280 (23.5)	9,600 (42.7)	14,880 (66.2)	21,120 (93.9)	28,800 (128.1)	37,920 (168.7)	48,000 (213.5)	60,960 (271.2)
	Reduction Factor for Seismic Shear	$aV_{,seis}$	-	0.70	0.74	0.78	0.82	0.73	0.63	0.53	0.42
	Strength Reduction Factor for Tension <sup>3</sup>	$\phi$	-	0.75							
	Strength Reduction Factor for Shear <sup>3</sup>	$\phi$	-	0.65							
ASTM A615 Grade 60	Nominal Strength as Governed by Steel Strength	$N_{sa}$	lb. (kN)	9,900 (44.0)	18,000 (80.1)	27,900 (124.1)	39,600 (176.1)	54,000 (240.2)	71,100 (316.3)	90,000 (400.3)	114,300 (508.4)
		$V_{sa}$	lb. (kN)	5,280 (23.5)	9,600 (42.7)	14,880 (66.2)	23,760 (105.7)	32,400 (144.1)	42,660 (189.8)	54,000 (240.2)	68,580 (305.1)
	Reduction Factor for Seismic Shear	$aV_{,seis}$	-	0.70	0.74	0.78	0.82	0.73	0.63	0.53	0.42
	Strength Reduction Factor for Tension <sup>3</sup>	$\phi$	-	0.65							
	Strength Reduction Factor for Shear <sup>3</sup>	$\phi$	-	0.60							
ASTM A615 Grade 75	Nominal Strength as Governed by Steel Strength	$N_{sa}$	lb. (kN)	11,000 (48.9)	20,000 (89.0)	31,000 (137.9)	44,000 (195.7)	60,000 (266.9)	79,000 (351.4)	100,000 (444.8)	127,000 (564.9)
		$V_{sa}$	lb. (kN)	6,600 (53.4)	12,000 (29.4)	18,600 (82.7)	26,400 (117.4)	36,000 (160.1)	47,400 (210.8)	60,000 (266.9)	76,200 (339.0)
	Reduction Factor for Seismic Shear	$aV_{,seis}$	-	0.70	0.74	0.78	0.82	0.73	0.63	0.53	0.42
	Strength Reduction Factor for Tension <sup>3</sup>	$\phi$	-	0.65							
	Strength Reduction Factor for Shear <sup>3</sup>	$\phi$	-	0.60							

**EF600**

HIGH PERFORMANCE STRUCTURAL PURE EPOXY

**TECHNICAL DATA****TABLE 19: EF600 STEEL DESIGN INFORMATION FOR REBAR<sup>1</sup>**

For SI: 1 inch = 25.4 mm, 1 lbf = 4.448 N, 1 psi = 0.006897 MPa

For pound-inch units: 1 mm = 0.03937 inch, 1 N = 0.2248 lbf, 1 MPa = 145.0 psi

1. Values provided for common rod material types are based on specified strength and calculated in accordance with ACI 318-14 Eq. 17.4.1.2 and Eq. 17.5.1.2b or ACI 318-11 Eq. (D-2) and Eq. (D-29), as applicable. Nuts and washers must be appropriate for the rod strength and type.
2. Cross-sectional area is minimum stress area applicable for either tension or shear.
3. For use with load combinations of IBC Section 1605.2, ACI 318-14 5.3 or ACI 318-11 9.2, as applicable, as set forth in ACI 318-14 17.3.3 or ACI 318-11 D.4.3. If the load combinations of ACI 318-11 Appendix C are used, the appropriate value of must be determined in accordance with ACI 318-11 D4.4. Values correspond to a ductile steel element.
4. For use with load combinations of IBC Section 1605.2, ACI 318-14 5.3 or ACI 318-11 9.2, as applicable, as set forth in ACI 318-14 17.3.3 or ACI 318-11 D.4.3. If the load combinations of ACI 318-11 Appendix C are used, the appropriate value of must be determined in accordance with ACI 318-11 D4.4. Values correspond to a brittle steel element.



**TECHNICAL DATA**

**TABLE 20: EF600 CONCRETE BREAKOUT DESIGN INFORMATION FOR REBAR, IN HOLES DRILLED WITH A HAMMER DRILL & CARBIDE BIT**

DESIGN INFORMATION	SYMBOL	UNIT	REBAR							
			#3	#4	#5	#6	#7	#8	#9	#10
Minimum Embedment Depth	$h_{er,min}$	in. (mm)	2-3/8 (60)	2-3/4 (70)	3-1/8 (79)	3-1/2 (89)	3-1/4 (95)	4 (102)	4-1/2 (114)	5 (127)
Maximum Embedment Depth	$h_{er,max}$	in. (mm)	7-1/2 (191)	10 (254)	12-1/2 (318)	15 (381)	17-1/2 (445)	20 (508)	22-1/2 (572)	25 (635)
Effectiveness Factor for Cracked Concrete	$k_{c,cr}$	- SI	17 (7.1)							
Effectiveness Factor for Uncracked Concrete	$k_{c,uncr}$	- SI	24 (10)							
Minimum Spacing Distance	$s_{min}$	in. (mm)	$s_{min} = c_{min}$							
Minimum Edge Distance	$c_{min}$	in. (mm)	2-3/16 (56)	2-13/16 (71)	3-3/4 (95)	4-3/8 (111)	5 (127)	5-5/8 (143)	6-1/4 (159)	6-7/8 (175)
Minimum Concrete Thickness	$h_{min}$	in. (mm)	hef + 1.25, [ ≥ .937 ] (hef + 30, [ ≥ 100 ])		$h_{ef} + 2d_o$ where $d_o$ is the hole diameter					
Critical Edge Distance (Uncracked Concrete Only)	$c_{ac}$	in.	$C_{ac} = h_{ef} \cdot \left( \frac{\min(\tau_{k,uncr}; \tau_{k,max})}{1160} \right)^{0.4} \cdot \max \left[ \left( 3.1 - 0.7 \frac{h}{h_{ef}} \right); 1.4 \right]$							
		mm	$C_{ac} = h_{ef} \cdot \left( \frac{\min(\tau_{k,uncr}; \tau_{k,max})}{8} \right)^{0.4} \cdot \max \left[ \left( 3.1 - 0.7 \frac{h}{h_{ef}} \right); 1.4 \right]$							
Strength Reduction Factor for Tension, Concrete Failure Mode, Condition B <sup>1</sup>	$\phi$	-	0.65							
Strength Reduction Factor for Shear, Concrete Failure Mode, Condition B <sup>1</sup>	$\phi$	-	0.70							

For SI: 1 inch = 25.4 mm, 1lbf = 4.448 N, 1 psi = 0.006897 MPa  
 For pound-inch units: 1 mm = 0.03937 inch, 1 N = 0.2248 lbf, 1MPa = 145.0 psi

- Values provided for post-installed anchors with category as determined from ACI 355.4 given for Condition B. Condition B applies without supplementary reinforcement or where pullout (bond) or pryout govern, as set forth in ACI 318-14 17.3.3 or ACI 318-11 D.4.3, as applicable, while condition A requires supplemental reinforcement. Values are for use with the load combinations Section 1605.2 of the IBC, ACI 318-14 5.3 or ACI 318-11 Section 9.2, as applicable, as set forth in ACI 318-11 D.4.3. If the load combinations of ACI 318-11 Appendix C are used, the appropriate value of must be determined in accordance with ACI 318-11 D.4.4.



**TECHNICAL DATA**

**TABLE 21: EF600 BOND STRENGTH DESIGN INFORMATION FOR REBAR IN HOLES DRILLED WITH A HAMMER DRILL & CARBIDE BIT - MAXIMUM LONG TERM SERVICE TEMPERATURE 110°F (43°C)<sup>1,2,3,4</sup>**

DESIGN INFORMATION			SYMBOL	UNIT	REBAR							
					#3	#4	#5	#6	#7	#8	#9	#10
Minimum Embedment Depth			$h_{ef,min}$	in. (mm)	2-3/8 (60)	2-3/4 (70)	3-1/8 (79)	3-1/2 (89)	3-1/4 (95)	4 (102)	4-1/2 (114)	5 (127)
Maximum Embedment Depth			$h_{ef,max}$	in. (mm)	7-1/2 (191)	10 (254)	12-1/2 (318)	15 (381)	17-1/2 (445)	20 (508)	22-1/2 (572)	25 (635)
Maximum Short Term Temp. 150°F (66°C)	Cracked Concrete Characteristic Bond Strength	With Sustained Load	$T_{k,cr}$	psi (MPa)	1,450 (10.0)	1,420 (9.8)	1,400 (9.7)	1,365 (9.4)	1,295 (8.9)	1,230 (8.5)	1,160 (8.0)	1,080 (7.4)
		No Sustained Load		psi (MPa)	1,665 (11.5)	1,635 (11.3)	1,605 (11.1)	1,570 (10.8)	1,490 (10.3)	1,410 (9.7)	1,330 (9.2)	1,240 (8.5)
	Uncracked Concrete Characteristic Bond Strength	With Sustained Load	$T_{k,uncr}$	psi (MPa)	2,180 (15.0)	2,095 (14.4)	2,010 (13.9)	1,930 (13.3)	1,845 (12.7)	1,760 (12.1)	1,675 (11.5)	1,580 (10.9)
		No Sustained Load		psi (MPa)	2,505 (17.3)	2,405 (16.6)	2,310 (15.9)	2,215 (15.3)	2,120 (15.3)	2,020 (13.9)	2,925 (13.3)	2,815 (12.5)
Maximum Short Term Temp. 180°F (82°C)	Cracked Concrete Characteristic Bond Strength	With Sustained Load	$T_{k,cr}$	psi (MPa)	1,275 (8.8)	1,255 (8.7)	1,230 (8.5)	1,205 (8.3)	1,140 (7.9)	1,080 (7.4)	1,020 (7.0)	950 (6.6)
		No Sustained Load		psi (MPa)	1,465 (10.1)	1,440 (9.9)	1,415 (9.8)	1,380 (9.5)	1,310 (9.0)	12,40 (8.5)	1,170 (8.1)	1,090 (7.5)
	Uncracked Concrete Characteristic Bond Strength	With Sustained Load	$T_{k,uncr}$	psi (MPa)	1,920 (13.2)	1,845 (12.7)	1,770 (12.2)	1,700 (11.7)	1,625 (11.2)	1,550 (10.7)	1,475 (10.2)	1,390 (9.6)
		No Sustained Load		psi (MPa)	2,205 (15.2)	2,120 (14.6)	2,205 (15.2)	1,950 (13.4)	1,865 (12.9)	1,780 (12.30)	1,695 (11.7)	1,595 (11.0)
Maximum Short Term Temp. 205°F (96°C)	Cracked Concrete Characteristic Bond Strength	With Sustained Load	$T_{k,cr}$	psi (MPa)	545 (3.8)	535 (3.7)	525 (3.6)	515 (3.6)	485 (3.3)	460 (3.2)	435 (3.0)	405 (2.8)
		No Sustained Load		psi (MPa)	625 (4.3)	615 (4.2)	600 (4.1)	590 (4.1)	560 (3.9)	530 (3.7)	500 (3.4)	465 (3.2)
	Uncracked Concrete Characteristic Bond Strength	With Sustained Load	$T_{k,uncr}$	psi (MPa)	820 (5.7)	785 (5.4)	755 (5.2)	725 (5.0)	690 (4.8)	660 (4.6)	630 (4.3)	590 (4.1)
		No Sustained Load		psi (MPa)	940 (6.5)	905 (6.2)	865 (6.0)	830 (5.7)	795 (5.5)	760 (5.2)	720 (5.0)	680 (4.7)

CONTINUES ON NEXT PAGE...



**TECHNICAL DATA**

**TABLE 21: EF600 BOND STRENGTH DESIGN INFORMATION FOR REBAR IN HOLES DRILLED WITH A HAMMER DRILL & CARBIDE BIT - MAXIMUM LONG TERM SERVICE TEMPERATURE 110°F (43°C)<sup>1,2,3,4</sup>**

DESIGN INFORMATION			SYMBOL	UNIT	REBAR						
					#3	#4	#5	#6	#7	#8	#9
Reduction Factor for Seismic Tension <sup>5</sup>			$aN_{n,seis}$	-	1.00				0.97		0.96
Continuous Inspection	Strength Reduction Factors for Permissible Installation Conditions <sup>6,7,8</sup>	Dry Concrete	$\phi_d$	-	0.65						
		Water Saturated Concrete	$\phi_{ws}$	-	0.65		0.55				
		Water Filled Holes in Concrete	$\phi_{wf}$	-	0.55				0.45		
			$K_{wf}$	-	1.00				0.96	0.92	0.88
		Underwater Holes In Concrete	$\phi_{uw}$	-	0.65						
Periodic Inspection	Strength Reduction Factors for Permissible Installation Conditions <sup>6,7,8</sup>	Dry Concrete	$\phi_d$	-	0.65						
		Water Saturated Concrete	$\phi_{ws}$	-	0.55		0.45				
		Water Filled Holes in Concrete	$\phi_{wf}$	-	0.45						
			$K_{wf}$	-	1.00				0.92	0.83	0.75
		Underwater Holes In Concrete	$\phi_{uw}$	-	0.55						

For SI: 1 inch = 25.4 mm, 1 lbf = 4.448 N, 1 psi = 0.006897 MPa

For pound-inch units: 1 mm = 0.03937 inch, 1 N = 0.2248 lbf, 1MPa = 145.0 psi

1. Characteristic bond strength values correspond to concrete compressive strength  $f_c = 2,500$  psi (17.2 MPa). For uncracked concrete compressive strength  $f_c$  between 2,500 psi (17.2 MPa) and 8,000 psi (55.2 MPa), the tabulated characteristic bond strength may be increased by a factor of  $(f_c / 2,500)0.1$  (for SI:  $(f_c / 17.2)0.1$ ). For cracked concrete, no increase in bond strength is permitted.
2. Lightweight concrete may be used by applying a reduction factor as given in ACI 318-14 17.2.6 or ACI 318-11 Appendix D section D3.6 as applicable.
3. Short term elevated concrete temperatures are those that occur over brief intervals, e.g., as a results of diurnal cycling. Long term concrete temperatures are roughly constant over significant periods of time.
4. Characteristic bond strength values are for sustained loads (when noted), including dead and live loads.
5. For structures in regions assigned to Seismic Design Category C, D, E, or F, the bond strength values shall be multiplied by  $\eta_{n,seis}$ .
6. The tabulated value  $\phi$  of applies when load combinations of Section 1605.2 of the IBC or ACI 318-14 5.3 (ACI 318-11 9.2), are used in accordance with ACI 318-14 17.3.3 (ACI 318-11 D.4.3). If the load combinations of ACI 318-11 Appendix C are used, the appropriate value of  $\phi$  shall be determined in accordance with ACI 318 D.4.4.
7. The values of  $\phi$  correspond to Condition B as described in ACI 318-14 17.3.3 (ACI 318-11 D.4.3) for post-installed anchors designed using the load combinations of IBC Section 1605.2. If the load combinations in ACI 318-11 Appendix C are used, the corresponding value of  $\phi$  shall be determined.
8. The values of  $\phi$  correspond to the anchor category as set forth in ACI 318-14 17.3.3 (ACI 318-11 D.4.3). The factor of 0.65 represents a Category 1, 0.55 a Category 2 and 0.45 a Category 3.



**TECHNICAL DATA**

**TABLE 22: EF600 BOND STRENGTH DESIGN INFORMATION FOR REBAR IN CORE DRILLED HOLES - MAXIMUM LONG TERM SERVICE TEMPERATURE 110°F (43°C)<sup>1,2,3,4</sup>**

DESIGN INFORMATION			SYMBOL	UNIT	REBAR							
					#3	#4	#5	#6	#7	#8	#9	#10
Minimum Embedment Depth			$h_{ef,min}$	in. (mm)	in. (mm)	2-3/4 (70)	3-1/8 (79)	3-1/2 (89)	3-1/4 (95)	4 (102)	4-1/2 (114)	5 (127)
Maximum Embedment Depth			$h_{ef,max}$	in. (mm)	in. (mm)	10 (254)	12-1/2 (318)	15 (381)	17-1/2 (445)	20 (508)	22-1/2 (572)	25 (635)
Maximum Short Term Temp. 150°F (66°C)	Uncracked Concrete Characteristic Bond Strength	With Sustained Load	$T_{k,uncr}$	psi (MPa)	psi (MPa)	1,535 (10.6)	1,490 (10.3)	1,380 (9.5)	1,270 (8.8)	1,160 (8.0)	1,045 (7.2)	920 (6.3)
		No Sustained Load		psi (MPa)	psi (MPa)	1,760 (12.1)	1,715 (11.8)	1,585 (10.9)	1,460 (10.1)	1,330 (9.2)	1,200 (8.3)	1,055 (7.3)
Maximum Short Term Temp. 180°F (82°C)	Uncracked Concrete Characteristic Bond Strength	With Sustained Load	$T_{k,uncr}$	psi (MPa)	psi (MPa)	1,350 (9.3)	1,315 (9.1)	1,215 (8.4)	1,120 (7.7)	1,020 (7.0)	920 (6.3)	810 (5.6)
		No Sustained Load		psi (MPa)	psi (MPa)	1,550 (10.7)	1,510 (10.4)	1,395 (9.6)	1,285 (8.9)	1,170 (8.1)	1,060 (7.3)	930 (6.4)
Continuous Inspection	Strength Reduction Factors for Permissible Installation Conditions <sup>6,7,8</sup>	Dry Concrete	$\Phi_d$	-	-	0.65						
		Wet Saturated Concrete	$\Phi_{ws}$	-	-	0.65						
Periodic Inspection	Strength Reduction Factors for Permissible Installation Conditions <sup>6,7,8</sup>	Dry Concrete	$\Phi_d$	-	-	0.65						
		Wet Saturated Concrete	$\Phi_{ws}$	-	-	0.65						

For SI: 1 inch = 25.4 mm, 1 lbf = 4.448 N, 1 psi = 0.006897 MPa

For pound-inch units: 1 mm = 0.03937 inch, 1 N = 0.2248 lbf, 1MPa = 145.0 psi

1. Characteristic bond strength values correspond to concrete compressive strength  $f'_c = 2,500$  psi (17.2 MPa). For uncracked concrete compressive strength  $f'_c$  between 2,500 psi (17.2 MPa) and 8,000 psi (55.2 MPa), the tabulated characteristic bond strength may be increased by a factor of  $(f'_c / 2,500)^{0.1}$  (for SI:  $(f'_c / 17.2)^{0.1}$ ). For cracked concrete, no increase in bond strength is permitted.
2. Lightweight concrete may be used by applying a reduction factor as given in ACI 318-14 17.2.6 or ACI 318-11 Appendix D section D3.6 as applicable.
3. Short term elevated concrete temperatures are those that occur over brief intervals, e.g., as a results of diurnal cycling. Long term concrete temperatures are roughly constant over significant periods of time.
4. Characteristic bond strength values are for sustained loads (when noted), including dead and live loads.
5. K factor not listed for conditions where  $K = 1.0$ .
6. The tabulated value of  $\Phi$  applies when load combinations of Section 1605.2 of the IBC or ACI 318-14 5.3 (ACI 318-11 9.2), are used in accordance with ACI 318-14 17.3.3 (ACI 318-11 D.4.3). If the load combinations of ACI 318-11 Appendix C are used, the appropriate value of shall be determined in accordance with ACI 318 D.4.4.
7. The values of  $\Phi$  correspond to Condition B as described in ACI 318-14 17.3.3 (ACI 318-11 D.4.3) for post-installed anchors designed using the load combinations of IBC Section 1605.2. If the load combinations in ACI 318-11 Appendix C are used, the corresponding value of shall be determined.
8. The values of  $\Phi$  correspond to the anchor category as set forth in ACI 318-14 17.3.3 (ACI 318-11 D.4.3). The factor of 0.65 represents a Category 1, 0.55 a Category 2 and 0.45 a Category 3.



**TECHNICAL DATA**

**TABLE 23: EF600 STEEL DESIGN INFORMATION FOR POWER-SERT INTERNALLY THREADED INSERTS<sup>1</sup>**

DESIGN INFORMATION		SYMBOL	UNIT	INSERT DESIGNATION				
				PS2-38	PS2-12	PS2-58	PS2-34	PS2-1
Internal Thread Size (UNC)		$d_t$	in. - TPI	3/8 - 16	1/2 - 13	5/8 - 11	3/4 - 10	1 - 8
Nominal Anchor Diameter		$d_a$	in. (mm)	0.488 (12.4)	0.595 (15.1)	0.819 (20.8)	0.898 (22.8)	1.450 (36.8)
Cross-Sectional Area <sup>2</sup>		$A_{se}$	in. <sup>2</sup> (mm <sup>2</sup> )	0.102 (66)	0.135 (87)	0.302 (195)	0.385 (248)	0.785 (506)
Specified Tensile Strength		$F_{uta}$	psi (MPa)	64,000 (440)				
Carbon Steel Inserts (PS2)	Nominal Strength as Governed by Steel Strength	$N_{sa}$	lb. (kN)	6,525 (29.0)	8,670 (38.6)	19,320 (85.9)	24,630 (109.6)	50,265 (223.6)
		$V_{sa}$	lb. (kN)	3,915 (17.4)	5,200 (23.1)	11,595 (51.6)	14,780 (65.7)	30,160 (134.2)
	Strength Reduction Factor for Tension <sup>3</sup>	$\phi$	-	0.75				
	Strength Reduction Factor for Shear <sup>3</sup>	$\phi$	-	0.65				
DESIGN INFORMATION		SYMBOL	UNITS	INSERT DESIGNATION				
				PS6-38	PS6-12	PS6-58	PS6-34	PS6-1
Specified Tensile Strength		$F_{uta}$	psi (MPa)	100,000 (690)			85,000 (590)	
316 Stainless Steel Inserts(PS6)	Nominal Strength as Governed by Steel Strength	$N_{sa}$	lb. (kN)	10,195 (45.3)	13,550 (60.3)	25,600 (114.1)	32,710 (145.5)	66,760 (297.0)
		$V_{sa}$	lb. (kN)	6,115 (27.2)	8,130 (36.2)	15,395 (68.5)	19,625 (87.3)	40,055 (178.2)
	Strength Reduction Factor for Tension <sup>3</sup>	$\phi$	-	0.65				
	Strength Reduction Factor for Shear <sup>3</sup>	$\phi$	-	0.60				

- Values provided for common rod material types are based on specified strength and calculated in accordance with ACI 318-14 Eq. 17.4.1.2 and Eq. 17.5.1.2b or ACI 318-11 Eq. (D-2) and Eq. (D-29), as applicable. Nuts and washers shall be appropriate for the rod strength and type.
- Cross-sectional area is minimum stress area applicable for either tension or shear.
- For use with load combinations of IBC Section 1605.2, ACI 318-14 5.3 or ACI 318-11 9.2, as applicable, as set forth in ACI 318-14 17.3.3 or ACI 318-11 D.4.3. If the load combinations of ACI 318-11 Appendix C are used, the appropriate value of shall be determined in accordance with ACI 318-11 D4.4. Values correspond to a ductile steel element.
- For use with load combinations of IBC Section 1605.2, ACI 318-14 5.3 or ACI 318-11 9.2, as applicable, as set forth in ACI 318-14 17.3.3 or ACI 318-11 D.4.3. If the load combinations of ACI 318-11 Appendix C are used, the appropriate value of shall be determined in accordance with ACI 318-11 D4.4. Values correspond to a brittle steel element.



**TECHNICAL DATA**

**TABLE 24: EF600 STEEL DESIGN INFORMATION FOR POWER-SERT INTERNALLY THREADED INSERTS<sup>1</sup>**

DESIGN INFORMATION	SYMBOL	UNIT	PS2-38 PS6-38	PS2-12 PS6-12	PS2-58 PS6-58	PS2-34 PS6-34	PS2-1 PS6-1
Internal Thread Size (UNC)	$d_t$	in. - TPI	3/8 - 16	1/2 - 13	5/8 - 11	3/4 - 10	1 - 8
Nominal Anchor Diameter	$d_a$	in. (mm)	0.488 (12.4)	0.595 (15.1)	0.819 (20.8)	0.898 (22.8)	1.450 (36.8)
Effective Embedment Depth for Concrete Breakout	$h_{ef}$	in. (mm)	2.5 (64)	3.5 (89)	5.5 (140)	6.2 (157)	8.2 (208)
Minimum Nominal Embedment Depth	$h_a$	in. (mm)	2-3/4 (70)	3-11/16 (94)	5-3/4 (146)	6-1/2 (165)	8-1/2 (216)
Effectiveness Factor for Uncracked Concrete	$k_{c,uncr}$	in. - lb. SI	24 (10)				
Minimum Spacing Distance	$s_{min}$	in. (mm)	$s_{min} = c_{min}$				
Minimum Edge Distance	$c_{min}$	in. (mm)	2-1/2 (64)	3-1/8 (79)	4-3/8 (111)	5 (127)	7-1/2 (191)
Minimum Concrete Thickness	$h_{min}$	in. (mm)	4-1/2 (114)	5-3/8 (137)	8 (203)	9-1/2 (241)	12-1/2 (318)
Critical Edge Distance (Uncracked Concrete Only)	$c_{ac}$	in.	$C_{ac} = h_{ef} \cdot \left( \frac{\min(\tau_{k,uncr}; \tau_{k,max})}{1160} \right)^{0.4} \cdot \max \left[ \left( 3.1 - 0.7 \frac{h}{h_{ef}} \right); 1.4 \right]$				
		mm	$C_{ac} = h_{ef} \cdot \left( \frac{\min(\tau_{k,uncr}; \tau_{k,max})}{8} \right)^{0.4} \cdot \max \left[ \left( 3.1 - 0.7 \frac{h}{h_{ef}} \right); 1.4 \right]$				
Strength Reduction Factor for Tension, Concrete Failure Mode, Condition B1	$\phi$	-	0.65				
Strength Reduction Factor for Shear, Concrete Failure Mode, Condition B1	$\phi$	-	0.70				

For SI: 1 inch = 25.4 mm, 1 lbf = 4.448 N, 1 psi = 0.006897 MPa

For pound-inch units: 1 mm = 0.03937 inch, 1 N = 0.2248 lbf, 1 MPa = 145.0 psi

- Values provided for post-installed anchors with category as determined from ACI 355.4 given for Condition B. Condition B applies without supplementary reinforcement or where pullout (bond) or pryout govern, as set forth in ACI 318-14 17.3.3 or ACI 318-11 D.4.3, as applicable, while condition A requires supplemental reinforcement. Values are for use with the load combinations Section 1605.2 of the IBC, ACI 318-14 5.3 or ACI 318-11 Section 9.2, as applicable, as set forth in ACI 318-11 D.4.3. If the load combinations of ACI 318-11 Appendix C are used, the appropriate value of  $\phi$  must be determined in accordance with ACI 318-11 D.4.4.



**TECHNICAL DATA**

**TABLE 25: EF600 BOND STRENGTH DESIGN INFORMATION FOR POWER-SERT INTERNALLY THREADED INSERT IN HOLES DRILL WITH A HAMMER DRILL & CARBIDE BIT - MAXIMUM LONG TERM SERVICE TEMPERATURE 110°F (43°C)<sup>1,2,3,4</sup>**

DESIGN INFORMATION			SYMBOL	UNIT	PS2-38 PS6-38	PS2-12 PS6-12	PS2-58 PS6-58	PS2-34 PS6-34	PS2-1 PS6-1
Internal Thread Size (UNC)			$d_t$	in. - TPI	3/8 - 16	1/2 - 13	5/8 - 11	3/4 - 10	1 - 8
Anchor Diameter			$d_a$	in. (mm)	0.488 (12.4)	0.595 (15.1)	0.819 (20.8)	0.898 (22.8)	1.450 (36.8)
Drill Bit Diameter			$d_o$	in.	1/2	5/8	7/8	1	1-1/2
Recommended Drill Depth			$h_{drill}$	in. (mm)	3-1/4 (83)	4-1/8 (105)	6-1/4 (159)	7-1/2 (191)	9-1/2 (241)
Overall Anchor Length			$h_a$	in. (mm)	2-3/4 (70)	3-11/16 (94)	5-3/4 (146)	6-1/2 (165)	8-1/2 (216)
Bond Effective Embedment Depth			$h_{ef}$	in. (mm)	1.55 (39)	2.49 (63)	3.75 (95)	3.74 (95)	5.00 (127)
Maximum Short Term Temp. 150°F (66°C)	Uncracked Concrete Characteristic Bond Strength	With Sustained Load	$T_{k,uncr}$	psi (MPa)	2,410 (16.6)	2,325 (16.0)	2,150 (14.8)	2,090 (14.4)	1,655 (11.4)
		No Sustained Load		psi (MPa)	2,765 (19.1)	2,670 (18.4)	2,470 (17.0)	2,400 (16.5)	1,900 (13.1)
Maximum Short Term Temp. 180°F (82°C)	Uncracked Concrete Characteristic Bond Strength	With Sustained Load	$T_{k,uncr}$	psi (MPa)	2,120 (14.6)	2,045 (14.1)	1,895 (13.1)	1,840 (12.7)	1,460 (10.1)
		No Sustained Load		psi (MPa)	2,435 (16.8)	2,350 (16.2)	2,175 (15.0)	2,110 (14.5)	1,675 (11.5)
Maximum Short Term Temp. 205°F (96°C)	Uncracked Concrete Characteristic Bond Strength	With Sustained Load	$T_{k,uncr}$	psi (MPa)	905 (6.2)	870 (6.0)	805 (5.6)	785 (5.4)	620 (4.3)
		No Sustained Load		psi (MPa)	1,035 (7.1)	1,000 (6.9)	925 (6.4)	900 (6.2)	715 (4.9)
Continuous Inspection	Strength Reduction Factors for Permissible Installation Conditions <sup>6,7,8</sup>	Dry Concrete	$\phi_d$	-	0.65				
		Water Saturated Concrete	$\phi_{ws}$	-	0.65	0.55			
Periodic Inspection	Strength Reduction Factors for Permissible Installation Conditions <sup>6,7,8</sup>	Dry Concrete	$\phi_d$	-	0.65				
		Water Saturated Concrete	$\phi_{ws}$	-	0.55	0.45			

For SI: 1 inch = 25.4 mm, 1 lbf = 4.448 N, 1 psi = 0.006897 MPa For pound-inch units: 1 mm = 0.03937 inch, 1 N = 0.2248 lbf, 1MPa = 145.0 psi

- Characteristic bond strength values correspond to concrete compressive strength  $f_c = 2,500$  psi (17.2 MPa). For uncracked concrete compressive strength  $f_c$  between 2,500 psi (17.2 MPa) and 8,000 psi (55.2 MPa), the tabulated characteristic bond strength may be increased by a factor of  $(f_c / 2,500)^{0.1}$  (for SI:  $(f_c / 17.2)^{0.1}$ ).
- Lightweight concrete may be used by applying a reduction factor as given in ACI 318-14 17.2.6 or ACI 318-11 Appendix D section D3.6 as applicable.
- Short term elevated concrete temperatures are those that occur over brief intervals, e.g., as a results of diurnal cycling. Long term concrete temperatures are roughly constant over significant periods of time.
- Characteristic bond strength values are for sustained loads (when noted), including dead and live loads.
- For structures in regions assigned to Seismic Design Category C, D, E, or F, the bond strength values shall be multiplied by  $\eta_{seis}$ .
- The tabulated value of  $\phi$  applies when load combinations of Section 1605.2 of the IBC or ACI 318-14 5.3 (ACI 318-11 9.2), are used in accordance with ACI 318-14 17.3.3 (ACI 318-11 D.4.3). If the load combinations of ACI 318-11 Appendix C are used, the appropriate value  $\phi$  of shall be determined in accordance with ACI 318 D.4.4.
- The values of  $\phi$  correspond to Condition B as described in ACI 318-14 17.3.3 (ACI 318-11 D.4.3) for post-installed anchors designed using the load combinations of IBC Section 1605.2. If the load combinations in ACI 318-11 Appendix C are used, the corresponding value of shall be determined.
- The values of  $\phi$  correspond to the anchor category as set forth in ACI 318-14 17.3.3 (ACI 318-11 D.4.3). The factor of 0.65 represents a Category 1, 0.55 a Category 2 and 0.45 a Category 3.



**TECHNICAL DATA**

**TABLE 26: EF600 ALLOWABLE TENSION LOADS FOR THREADED ROD, IN HOLES DRILLED WITH A HAMMER DRILL, IN NORMAL WEIGHT CONCRETE<sup>1</sup>**

THREADED ROD DIAMETER in.	NOMINAL DRILL BIT DIAMETER in.	EMBEDMENT DEPTH in. (mm)		ALLOWABLE TENSION LOAD BASED ON BOND STRENGTH/CONCRETE CAPACITY <sup>2,3</sup> lbs. (kN)		ALLOWABLE TENSION LOAD BASED ON STEEL STRENGTH <sup>4</sup>		
				f'c = 2,500 psi (17.4 MPa)		ASTM F1554 GRADE 36 lbs. (kN)	ASTM A193 GRADE B7 lbs. (kN)	ASTM F593 304/316 SS lbs. (kN)
3/8	7/16	2-3/8	(60)	1,681	(7.5)	2,114 (9.4)	4,556 (20.3)	36,45 (16.2)
		3-3/8	(86)	2,655	(11.8)			
		4-1/2	(114)	3,858	(17.2)			
		7-1/2	(191)	7,838	(34.9)			
1/2	9/16	2-3/4	(70)	2,282	(10.2)	3,758 (16.7)	8,099 (36.0)	6,480 (28.8)
		4-1/2	(114)	4,329	(19.3)			
		6	(152)	6,292	(28.0)			
		10	(254)	12,266	(54.6)			
5/8	3/4	3-1/8	(79)	2,911	(13.0)	5,758 (26.1)	12,655 (56.3)	10,124 (45.0)
		5-5/8	(143)	6,326	(28.1)			
		7-1/2	(191)	9,195	(40.9)			
		12-1/2	(318)	17,863	(79.5)			
3/4	7/8	3-1/2	(86)	3,457	(13.7)	8,456 (37.6)	18,224 (81.1)	12,392 (55.1)
		6-3/4	(171)	8,625	(38.4)			
		9	(229)	12,536	(55.8)			
		15	(381)	24,354	(108.3)			
7/8	1	3-3/4	(95)	3,827	(17.0)	11,509 (51.2)	24,804 (110.3)	16,867 (75.0)
		7-7/8	(200)	11,209	(49.9)			
		10-1/2	(267)	16,292	(72.5)			
		17-1/2	(445)	31,650	(140.8)			
1	1-1/8	4	(102)	4,216	(18.8)	15,033 (66.9)	32,398 (144.1)	22,030 (98.0)
		9	(229)	14,065	(62.6)			
		12	(305)	20,444	(90.9)			
		20	(508)	39,716	(176.7)			
1-1/4	1-3/8	5	(127)	5,892	(26.2)	23,488 (104.5)	50,621 (225.2)	34,423 (153.1)
		11-1/4	(286)	19,887	(88.5)			
		15	(381)	29,875	(132.9)			
		25	(635)	58,038	(258.2)			

For SI: 1 inch = 25.4 mm, 1lbf = 4.448 N, 1 psi = 0.006897 MPa

For pound-inch units: 1 mm = 0.03937 inch, 1 N = 0.2248 lbf, 1MPa = 145.0 psi

1. The lower value of either the allowable bond strength/concrete capacity or steel strength should be used as the allowable tension value for design.

2. Allowable tension loads calculated based on strength design provisions of IBC Section 1605.3 with the following assumptions: Maximum short term temperature = 150 °F (66 °C), Maximum long term temperature = 110 °F (43°C). Load combination from ACI based on 1.2D + 1.6L assuming dead load of 0.3 and live load of 0.7 giving a weighted average of 1.48. f'c = 2,500 psi normal-weight uncracked concrete. Single anchor, drilled with either hammer drill or carbide bit, vertically down with periodic special inspection and no seismic loading. d = 0.65 for dry concrete, Ca1 ~ 1.5 x hef, hmin ~ 1.5 x Ca1, Ca2 ~ 1.5 x Ca1. Load values based on characteristic uncracked bond strength with sustained load.

3. For short term temperature exposure greater than 150 °F (66 °C) and up to and including 180 °F (82 °C), apply a reduction factor of 0.88 to the allowable tension load. For short term temperature exposure greater than 180 °F (82 °C) and up to and including 205 °F (96 °C), apply a reduction factor of 0.375 to the allowable tension load.

4. Allowable steel strengths calculated in accordance with AISC Manual of Steel Construction: Tensile = 0.33 \* Fu \* Anom.



**TECHNICAL DATA**

**TABLE 27: EF600 ALLOWABLE SHEAR LOADS FOR THREADED ROD, IN HOLES DRILLED WITH A HAMMER DRILL, IN NORMAL WEIGHT CONCRETE<sup>1</sup>**

THREADED ROD DIAMETER in.	NOMINAL DRILL BIT DIAMETER in.	EMBEDMENT DEPTH in. (mm)		ALLOWABLE SHEAR LOAD BASED ON BOND STRENGTH/CONCRETE CAPACITY <sup>2,3</sup> lbs. (kN)		ALLOWABLE SHEAR LOAD BASED ON STEEL STRENGTH <sup>4</sup>		
				f'c = 2,500 psi (17.4 MPa)		ASTM F1554 GRADE 36 lbs. (kN)	ASTM A193 GRADE B7 lbs. (kN)	ASTM F593 304/316 SS lbs. (kN)
3/8	7/16	2-3/8	(60)	1,608	(7.2)	1,089 (4.8)	2,347 (10.4)	1,878 (8.4)
		3-3/8	(86)	3,140	(14.0)			
		4-1/2	(114)	5,006	(22.3)			
		7-1/2	(191)	11,272	(50.1)			
1/2	9/16	2-3/4	(70)	2,401	(10.2)	1,936 (8.6)	4,172 (18.6)	3,338 (14.8)
		4-1/2	(114)	5,780	(25.7)			
		6	(152)	9,152	(40.7)			
		10	(254)	20,407	(90.8)			
5/8	3/4	3-1/8	(79)	2,401	(10.7)	3,025 (13.5)	6,519 (29.0)	5,216 (23.2)
		5-5/8	(143)	5,780	(25.7)			
		7-1/2	(191)	9,195	(40.7)			
		12-1/2	(318)	20,407	(90.8)			
3/4	7/8	3-1/2	(86)	4,024	(13.7)	4,356 (19.4)	9,388 (41.8)	6,384 (28.4)
		6-3/4	(171)	12,832	(57.1)			
		9	(229)	20,286	(90.2)			
		15	(381)	45,142	(200.8)			
7/8	1	3-3/4	(95)	4,687	(20.8)	5,929 (26.4)	12,778 (56.8)	8,689 (38.7)
		7-7/8	(200)	16,205	(72.1)			
		10-1/2	(267)	25,605	(113.9)			
		17-1/2	(445)	56,946	(253.3)			
1	1-1/8	4	(102)	5,255	(23.4)	7,744 (34.4)	16,690 (74.2)	11,349 (50.5)
		9	(229)	19,830	(88.2)			
		12	(305)	31,323	(139.3)			
		20	(508)	69,631	(309.7)			
1-1/4	1-3/8	5	(127)	7,374	(32.8)	12,100 (55.8)	26,078 (116.0)	17,733 (78.9)
		11-1/4	(286)	27,774	(123.5)			
		15	(381)	43,852	(195.1)			
		25	(635)	97,421	(433.4)			

For SI: 1 inch = 25.4 mm, 1lbf = 4.448 N, 1 psi = 0.006897 MPa

For pound-inch units: 1 mm = 0.03937 inch, 1 N = 0.2248 lbf, 1MPa = 145.0 psi

- The lower value of either the allowable bond strength/concrete capacity or steel strength should be used as the allowable tension value for design.
- Allowable tension loads calculated based on strength design provisions of IBC Section 1605.3 with the following assumptions: Maximum short term temperature = 150 °F (66 °C), Maximum long term temperature = 110 °F (43°C). Load combination from ACI based on 1.2D + 1.6L assuming dead load of 0.3 and live load of 0.7 giving a weighted average of 1.48. f'c = 2,500 psi normal-weight uncracked concrete. Single anchor, drilled with either hammer drill or carbide bit, vertically down with periodic special inspection and no seismic loading. d = 0.65 for dry concrete, Ca1 ~ 1.5 x hef, hmin ~ 1.5 x Ca1, Ca2 ~ 1.5 x Ca1. Load values based on characteristic uncracked bond strength with sustained load.
- For short term temperature exposure greater than 150 °F (66 °C) and up to and including 180 °F (82 °C), apply a reduction factor of 0.88 to the allowable tension load. For short term temperature exposure greater than 180 °F (82 °C) and up to and including 205 °F (96 °C), apply a reduction factor of 0.375 to the allowable tension load.
- Allowable steel strengths calculated in accordance with AISC Manual of Steel Construction: Tensile = 0.33 \* Fu \* Anom.



**TECHNICAL DATA**

**TABLE 28: EF600 ALLOWABLE TENSION LOADS FOR REBAR, IN HOLES DRILLED WITH A HAMMER DRILL, IN NORMAL WEIGHT CONCRETE<sup>1</sup>**

REBAR SIZE	NOMINAL DRILL BIT DIAMETER in.	EMBEDMENT DEPTH in. (mm)		ALLOWABLE TENSION LOAD BASED ON BOND STRENGTH/CONCRETE CAPACITY <sup>2,3</sup>		ALLOWABLE TENSION LOAD BASED ON STEEL STRENGTH <sup>4</sup>	
				lbs. (kN)		ASTM F1554 GRADE 36 lbs. (kN)	ASTM A193 GRADE B7 lbs. (kN)
				f'c = 2,500 psi (17.4 MPa)			
#3	1/2	2-3/8	(60)	1,805	(8.0)	2,640 (11.7)	3,300 (14.7)
		3-3/8	(86)	2,777	(12.0)		
		4-1/2	(114)	3,150	(14.0)		
		7-1/2	(191)	5,344	(23.8)		
#4	5/8	2-3/4	(70)	2,403	(10.7)	4,800 (21.4)	6,000 (26.7)
		4-1/2	(114)	4,431	(19.7)		
		6	(152)	5,071	(22.6)		
		10	(254)	8,308	(37.0)		
#5	3/4	3-1/8	(79)	2,911	(13.0)	7,440 (33.1)	9,300 (41.4)
		5-5/8	(143)	6,335	(28.2)		
		7-1/2	(191)	7,314	(32.5)		
		12-1/2	(318)	11,731	(52.2)		
#6	7/8	3-1/2	(86)	3,451	(15.4)	10,560 (47.0)	13,200 (58.7)
		6-3/4	(171)	8,449	(37.6)		
		9	(229)	9,842	(43.8)		
		15	(381)	15,591	(69.4)		
#7	1-1/8	3-3/4	(95)	3,827	(17.0)	14,400 (64.1)	18,000 (80.1)
		7-7/8	(200)	10,757	(47.8)		
		10-1/2	(267)	12,632	(56.2)		
		17-1/2	(445)	19,944	(88.7)		
#8	1-1/4	4	(102)	4,216	(18.8)	18,960 (84.3)	23,700 (105.4)
		9	(229)	13,205	(58.7)		
		12	(305)	15,642	(69.6)		
		20	(508)	24,864	(110.6)		
#9	1-3/8	4-1/2	(114)	5,031	(22.4)	24,000 (106.8)	30,000 (133.4)
		10-1/8	(257)	15,782	(70.2)		
		13-1/2	(343)	18,853	(83.9)		
		22-1/2	(572)	30,175	(134.2)		
#10	1-1/2	5	(127)	5,892	(26.2)	30,480 (135.6)	38,100 (169.5)
		11-1/4	(286)	18,395	(81.8)		
		15	(381)	22,192	(98.7)		
		25	(635)	35,807	(159.3)		



**TECHNICAL DATA**

**TABLE 28: EF600 ALLOWABLE TENSION LOADS FOR REBAR, IN HOLES DRILLED WITH A HAMMER DRILL, IN NORMAL WEIGHT CONCRETE<sup>1</sup>**

For SI: 1 inch = 25.4 mm, 1lbf = 4.448 N, 1 psi = 0.006897 MPa

For pound-inch units: 1 mm = 0.03937 inch, 1 N = 0.2248 lbf, 1MPa = 145.0 psi

- The lower value of either the allowable bond strength/concrete capacity or steel strength should be used as the allowable tension value for design.
- Allowable tension loads calculated based on strength design provisions of IBC Section 1605.3 with the following assumptions: Maximum short term temperature = 150 °F (66 °C), Maximum long term temperature = 110 °F (43°C). Load combination from ACI based on 1.2D + 1.6L assuming dead load of 0.3 and live load of 0.7 giving a weighted average of 1.48.  $f'c = 2,500$  psi normal-weight uncracked concrete. Single anchor, drilled with either hammer drill or carbide bit, vertically down with periodic special inspection and no seismic loading  $d = 0.65$  for dry concrete,  $Ca1 \sim 1.5 \times hef$ ,  $hmin \sim 1.5 \times Ca1$ ,  $Ca2 \sim 1.5 \times Ca1$ . Load values based on characteristic uncracked bond strength with sustained load.
- For short term temperature exposure greater than 150 °F (66 °C) and up to and including 180 °F (82 °C), apply a reduction factor of 0.88 to the allowable tension load. For short term temperature exposure greater than 180 °F (82 °C) and up to and including 205 °F (96 °C), apply a reduction factor of 0.375 to the allowable tension load.
- Allowable steel strengths calculated in accordance with AISC Manual of Steel Construction:  $Tensile = 0.33 * Fu * Anom$ .

**TABLE 29: EF600 ALLOWABLE SHEAR LOADS FOR REBAR, IN HOLES DRILLED WITH A HAMMER DRILL, IN NORMAL WEIGHT CONCRETE<sup>1</sup>**

REBAR SIZE	NOMINAL DRILL BIT DIAMETER in.	EMBEDMENT DEPTH in. (mm)		ALLOWABLE SHEAR LOAD BASED ON BOND STRENGTH/CONCRETE CAPACITY <sup>2,3</sup>		ALLOWABLE SHEAR LOAD BASED ON STEEL STRENGTH <sup>4</sup>	
				lbs. (kN)		ASTM F1554 GRADE 36 lbs. (kN)	ASTM A193 GRADE B7 lbs. (kN)
				$f'c = 2,500$ psi (17.4 MPa)			
#3	1/2	2-3/8	(60)	1,608	(7.2)	1,683 (7.5)	1,870 (8.3)
		3-3/8	(86)	3,140	(14.0)		
		4-1/2	(114)	3,915	(17.4)		
		7-1/2	(191)	5,290	(23.5)		
#4	5/8	2-3/4	(70)	2,401	(10.7)	3,060 (13.6)	3,400 (15.1)
		4-1/2	(114)	5,780	(25.7)		
		6	(152)	7,016	(31.2)		
		10	(254)	9,388	(41.8)		
#5	3/4	3-1/8	(79)	3,163	(14.0)	4,743 (21.1)	5,270 (23.4)
		5-5/8	(143)	9,071	(40.4)		
		7-1/2	(191)	10,776	(47.9)		
		12-1/2	(318)	14,400	(64.1)		
#6	7/8	3-1/2	(86)	4,024	(13.7)	6,732 (29.9)	7,480 (33.3)
		6-3/4	(171)	12,574	(55.9)		
		9	(229)	14,908	(66.3)		
		15	(381)	19,906	(88.5)		
#7	1-1/8	3-3/4	(95)	4,687	(20.8)	9,180 (40.8)	10,200 (45.4)
		7-7/8	(200)	15,546	(69.1)		
		10-1/2	(267)	18,423	(81.9)		
		17-1/2	(445)	24,584	(109.4)		

CONTINUES ON NEXT PAGE...



**TECHNICAL DATA**

**TABLE 29: EF600 ALLOWABLE SHEAR LOADS FOR REBAR, IN HOLES DRILLED WITH A HAMMER DRILL, IN NORMAL WEIGHT CONCRETE<sup>1</sup>**

REBAR SIZE	NOMINAL DRILL BIT DIAMETER in.	EMBEDMENT DEPTH in. (mm)		ALLOWABLE SHEAR LOAD BASED ON BOND STRENGTH/CONCRETE CAPACITY <sup>2,3</sup>		ALLOWABLE SHEAR LOAD BASED ON STEEL STRENGTH <sup>4</sup>	
				lbs. (kN)		ASTM F1554 GRADE 36 lbs. (kN)	ASTM A193 GRADE B7 lbs. (kN)
				f'c = 2,500 psi (17.4 MPa)			
#8	1-1/4	4	(102)	5,255	(23.4)	12,087 (53.8)	13,430 (59.7)
		9	(229)	18,580	(82.6)		
		12	(305)	22,011	(97.9)		
		20	(508)	29,359	(130.6)		
#9	1-3/8	4-1/2	(114)	6,285	(28.0)	15,300 (68.1)	17,000 (75.6)
		10-1/8	(257)	21,655	(96.3)		
		13-1/2	(343)	25,648	(114.1)		
		22-1/2	(572)	34,197	(152.1)		
#10	1-1/2	5	(127)	7,374	(32.8)	19,431 (86.4)	21,590 (96.0)
		11-1/4	(286)	24,618	(109.5)		
		15	(381)	29,151	(129.7)		
		25	(635)	38,858	(172.8)		

For SI: 1 inch = 25.4 mm, 1lbf = 4.448 N, 1 psi = 0.006897 MPa

For pound-inch units: 1 mm = 0.03937 inch, 1 N = 0.2248 lbf, 1MPa = 145.0 psi

- The lower value of either the allowable bond strength/concrete capacity or steel strength should be used as the allowable shear value for design.
- Allowable shear loads calculated based on strength design provisions of IBC Section 1605.3 with the following assumptions: Maximum short term temperature = 150 °F (66 °C), Maximum long term temperature = 110 °F (43°C). Load combination from ACI based on 1.2D + 1.6L assuming dead load of 0.3 and live load of 0.7 giving a weighted average of 1.48. f'c = 2,500 psi normal-weight uncracked concrete. Single anchor, drilled with either hammer drill or carbide bit, vertically down with periodic special inspection and no seismic loading d = 0.65 for dry concrete, Ca1 ~ 1.5 x hef, hmin ~ 1.5 x Ca1, Ca2 ~ 1.5 x Ca1. Load values based on characteristic uncracked bond strength with sustained load.
- For short term temperature exposure greater than 150 °F (66 °C) and up to and including 180 °F (82 °C), apply a reduction factor of 0.88 to the allowable tension load. For short term temperature exposure greater than 180 °F (82 °C) and up to and including 205 °F (96 °C), apply a reduction factor of 0.375 to the allowable tension load.
- Allowable steel strengths calculated in accordance with AISC Manual of Steel Construction: Shear = 0.17 \* Fu \* Anom.

**EF600**

HIGH PERFORMANCE STRUCTURAL PURE EPOXY



ICC ESR-4732

**DISCLAIMER**

**IMPORTANT:** Information, specifications, procedures and recommendations provided (“information”) are based on our experience and we believe this to be accurate. No representation, guarantee or warranty is made as to the accuracy or completeness of the information or that use of the product will avoid losses or damages or give desired results. It is purchaser’s sole responsibility to test and determine the suitability of any product for the intended use. Tests should be repeated if materials or conditions change in any way. No employee, distributor or agent has any right to change these facts and offer a guarantee of performance.

**NOTE TO USER:** by ordering/receiving product you accept the ALLFASTENERS General Terms and Conditions of Sale applicable in the region. Please request a copy if you have not received these. These Terms and Conditions contain disclaimers of implied warranties (including but not limited to disclaiming warranties of fitness for a particular purpose) and limits of liability.