

**NEXGEN2™ ONESIDE® BOLT**

MATERIAL SPECIFICATIONS & TESTING

NEXGEN2
ONESIDE BOLT

ALLFASTENERS NexGen2™ Oneside Bolt Assembly – Patent #10018212 and #9696478 – introduces a streamlined solution for one-sided installation of structural bolts. The NexGen2™ Oneside Bolt assembly has been specifically designed for the tower to provide full structural strength, guaranteed bolt tensioning and superior engagement of the shear sleeve into the shear plane every time.

The NexGen2™ Oneside Bolt Assembly was designed with efficiency in mind. The complete bolt assembly installs in just thirty seconds, saving your company precious time and money.



ICC-ESR 3975

PATENT #9696478, #10018212, #1105396 & #11781579

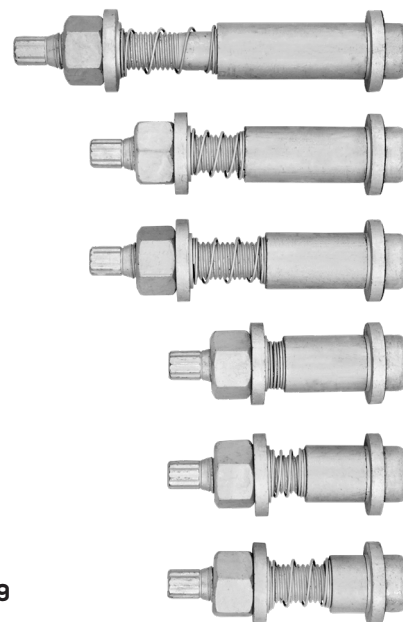
**KEY BENEFITS**

All structural components of the AF NexGen2™ Oneside Bolt Assembly meets their specified material requirements. The NG2 M20 bolt is made from the same material used in the production of ASTM A490. The design capacity of this product depends on the code or standard used by the engineer. The ultimate load capacity of this assembly has been verified per test ASTM F606-14 in tension and ASTM F606-14, NASM1312-20(11) in shear.

AISC steel code has long recognized Oneside Bolts in structural applications. Oneside Bolts features include the elimination for the need and use of nuts while installing. The shank of the fastener is inserted through the connection holes until the head bears out of the outer ply. In some situations, a special tool or wrench is used to open one side, keeping the shank from rotating, but simultaneously turning the threaded part of the assembly.

A wedge or other mechanism on the blind side causes the fixed part of the shank to expand and form a contact with the inside of the HSS. The AF Oneside Bolt Assembly contains a break off mechanism when the fastener is pretensioned.

- Superior structural Strength NexGen2™ M20 Bolt ASTM A490M
- High Tensile Steel Coil Spring
- Shear Sleeve ASTM A519 Grade4140
- Magni Coated Complete Assembly
- Available Lengths 60mm, 95mm, 135mm, 165mm, 250mm
- Guaranteed Tension Every Time
- Clean, Consistent Results
- Less Labor Required, Simple to Install
- Superior Strength & Economical
- Complete Bolt Assembly
- No Guesswork on Tensioning
- No Field Cutting Shear Sleeve
- No Bolt Slipping or Spinning
- Engagement of Shear Sleeve into the Shear Plane Every Time
- Full Shear Capacity of Hole
- Full Tension Capacity of Bolt
- Visual Inspection of correct Tension after Install
- No Lubricant Needed
- Made in the U.S.A.
- Patented Product (#10018212 & #9696478)



NEXGEN2™ ONESIDE® BOLT

MATERIAL SPECIFICATIONS & TESTING

1.0 RECOGNITION & CERTIFICATIONS

NexGen2™ Oneside Bolt Assembly evaluated in this report shows compliance to the following codes and regulations:

- ICC-ESR 3975
- 2018, 2015, 2012 and 2009 International Building Code® (IBC)
- 2013 Abu Dhabi International Building Code (ADIBC)

Property Evaluated: Structural

The ADIBC is based on the 2009 IBC. 2009 IBC code sections referenced in this report are the same sections in the ADIBC.

2.0 USES

AF NexGen2™ Oneside Bolt Assembly are designed for connecting structural steel to hollow structural steel elements where access is difficult or rescrited to one side only. NexGen2™ Oneside Bolts are intended for use with rectangular or square HSS members and are recognized for resisting tension and shear loads in bearing-type connections. NexGen2™ Oneside Bolt are alternatives to bolts described in Section J3 of AISC 360, which is referred in Section 2205.1 of IBC, for bearing-type connections.

The NexGen2™ Oneside Bolts may be used to resist wind loads, and seismic loads in Seismic Design Categories (SDC) A, B, and C in accordance with Section 1613.3.5 of the 2018, 2015 and 2012 IBC, and Section 1613.5.6 of the 2009 IBC.

3.0 DESCRIPTION

3.1 GENERAL

AF NexGen2™ Oneside Bolt Assembly are assembled from five components, consisting of a steel core bolt, a shear sleeve with steel spring, a hex nut, a solid collar washer and a collapsible split washer. The steel core bolt features a rounded head, threaded shank and tension control spline. The spring sleeve is a steel hollow cylinder with a premounted high tensile strength wire spring. The NexGen2™ Oneside Bolt nominal diameter is 20mm with lengths of 95, 135, 175 and 250mm.

3.2. MATERIALS

- 3.2.1 Core Bolt:** The core bolt is manufactured from steel complying with ASTM A490M with a minimum specified F_u of 150,000 psi (1034 MP_a), a 29mm outer diameter rounded head and a double hex splined end.
- 3.2.2 Shear Sleeve with Steel Spring:** The shear sleeve is manufactured from steel complying with ASTM A29 (4140) with a minimum specified F_u of 120,000 psi (827 MP_a). The steel spring is manufactured from wire complying with ASTM A228 with a 0.050 inch diameter. The spring is used to hold the shear sleeve in the correct position.
- 3.2.3 Hex Nut:** The hex nut is a prelubricated M20-2.50 heavy hex nut manufactured from steel complying with ASTM A194 2H.
- 3.2.4 Solid Collar Washer:** The solid collar washer is manufactured from steel complying with 1045 HRC 23-24.
- 3.2.5 Collapsible Split Washer:** The collapsible split washer is manufactured from steel complying with 1045 HRC 23-24.
- 3.2.6 Finish Coating:** All NexGen2™ Oneside Bolt components are Magni 554 duplex coated to a minimum thickness of 3 microns.



4.0 DESIGN & INSTALLATION

4.1 DESIGN

AF NexGen2™ Oneside Bolt Assembly are alternatives to bolts described in Section J3 of AISC 360, which is referenced in Section 2205.1 of the IBC, for bearing-type connections. The design of NexGen2™ Oneside Bolts must comply with this report, Section J3 AISC 360 and the strength design information for the NexGen2™ Oneside Bolts provided in this report. The load-carrying capacity of the assembly depends on the bolts, the type of steel elements connected (such as HSSs), and their cross sections (thickness). The design strength is limited by the strength of the weakest component in the bolt assembly, which includes the affected elements of the members and connecting elements and the bolts. The capacity may be governed by the affected elements and/or connecting elements in the case of thin sections, or the NexGen2™ Oneside Bolt in the case of thick wall sections (or a combination of the two). All limit states must be checked to determine the load-carrying capacity of the assembly. Combined tension and shear loading must comply with the following:

$$\left(\frac{\text{Tension Demand}}{\text{Tension Capacity}}\right)^2 + \left(\frac{\text{Shear Demand}}{\text{Shear Capacity}}\right)^2 \leq 1.0$$

4.2 INSTALLATION

The NexGen2™ Oneside Bolt Assembly must be installed in accordance with the details noted in this section, the manufacturer's installation instructions and approved plans.

1. Holes must be drilled into the steel sections to be connected, ensuring that the resulting holes have the correct diameter and spacing according to the manufacturer's published specifications, and the correct design requirements for the connection, as indicated in the approved plans. Holes must be 30 mm (1-3/16") diameter.
2. Burrs in the holes must be removed before insertion of the NexGen2™ Oneside Bolts. Field drilled holes shall be protected with cold-galvanized compound.
3. The structural steel elements to be connected must be positioned adjacent to each other to ensure that the two sections are lined up and bearing against the other without any gaps. Clamps may be used to hold the two steel sections together and prevent formation gaps.
4. The NexGen2™ Oneside Bolt must be installed in the holes in accordance with Figure 3.
5. Torque is applied until the bolt spline separates from the bolt.
6. The sheared bolt end of the NexGen2™ Oneside Bolt is protected with cold-applied galvanizing compound.

4.3 SPECIAL INSPECTION

Special inspection is required in accordance with Sections 1705.1 and 1705.2 of the 2018, 2015 and 2012 IBC (Sections 1704.3 and 1704.15 of the 2009 IBC). The manufacturer must submit inspection procedures to verify proper installation of the NexGen2™ Oneside Bolts. Where NexGen2™ Oneside Bolts are used for seismic or wind load resistance, special inspection requirements must comply with Sections 1704.3 and 1705 of the 2018, 2015 and 2012 IBC (Sections 1705, 1706, 1707 of the 2009 IBC).



NEXGEN2™ ONESIDE® BOLT

MATERIAL SPECIFICATIONS & TESTING

5.0 CONDITIONS OF USE

The NexGen2™ Oneside Bolts described in this report complies with, or is a suitable alternative to what is specified in, those codes listed in Section 1.0 of this report, subject to the following conditions:

- 5.1 Calculations and details showing that the NexGen2™ Oneside Bolts are adequate to resist the applied loads must be submitted to the code official for approval. The connected steel base materials and connecting steel elements also must be adequate to support the applied loads. The calculations and details must be signed and sealed by a registered design professional, when required by the statutes of the jurisdiction in which the project is to be constructed.
- 5.2 Fire resistive construction: Where not otherwise prohibited in the code, NexGen2™ Oneside Bolts are permitted for use with fire-resistance-rated construction provided that at least one of the following conditions is fulfilled:
 - NexGen2™ Oneside Bolts are used to resist wind or seismic forces only.
 - NexGen2™ Oneside Bolts that support a fire-resistance-rated envelope or fire-resistance-rated membrane, are protected by approved fire-resistance-rated materials, or have been evaluated for resistance to fire exposure in accordance with recognized standards.
 - NexGen2™ Oneside Bolts are used to support nonstructural elements.
- 5.3 Special inspection must be provided in accordance with Section 4.3 of this report.
- 5.4 Use of the NexGen2™ Oneside Bolts in applications where the applicable code requires slip-critical installation is beyond the scope of this report.
- 5.5 Corrosion resistance of the NexGen2 Oneside Bolts and connected steel elements is outside the scope of this evaluation.
- 5.6 Use of the NexGen2 Oneside Bolts is limited to Seismic Design Categories (SDC) A, B and C.

6.0 EVIDENCE SUBMITTED

Data in accordance with the ICC-ES Acceptance Criteria for Oneside Bolts in Structural Steel Connections (AC437 Concrete Elements (AC193), dated February 2019.

7.0 IDENTIFICATION

The NexGen2™ Oneside Bolt is identified by a seven character part number (2NGXXXX). The first three characters (2NG) indicate the product is an Allfasteners NexGen2™ Oneside Bolt, the next two digits denote the diameter and last two digits indicate the length. Each package of NexGen2™ Oneside Bolts includes the following information: NexGen2™ Oneside Bolt product nomenclature, quantity, part number, lot number, an image of the product and the evaluation report number (ESR-3975).



NEXGEN2™ ONESIDE® BOLT

MATERIAL SPECIFICATIONS & TESTING

PRODUCT INFORMATION

PART #	BOLT LENGTH (MM)	GRIP RANGE	SLEEVE LENGTH (IN)
2NG2060	M20 x 60	0.625 - 0.875 Standard (0.1875 - 0.875 with specification)*	0.500
2NG2032	M20 x 75	0.625 - 1.375	0.500
2NG2036	M20 x 95	0.9375 - 1.4375	0.6875
2NG2048	M20 x 95	1.4375 - 1.875	1.1875
2NG2057	M20 x 95	1.875 - 2.125	1.625
2NG2068	M20 x 135	2.125 - 2.6875	1.75
2NG2096	M20 x 135	2.6875 - 3.75	2.4375
2NG2127	M20 x 175	3.75 - 5.1875	3
2NG2212	M20 x 250	5 - 8.3125	4

* NOTE: Grip can be increased to 0.1875 - 0.875 with removal of collar. MUST specify this requirement at time of order, otherwise M20x60 will have standard grip range of 0.625-0.875.

PARTS



NG2™ Head Marking



NG2™ M20 Bolt
ASTM A490M



NG2™ Hex Nut
A194 2H



NG2™ Face Washer
1045 HRS 23-34



Collapsible Washer
1045 HRS 23-34



Spring Sleeve 4140
High Tensile Wire

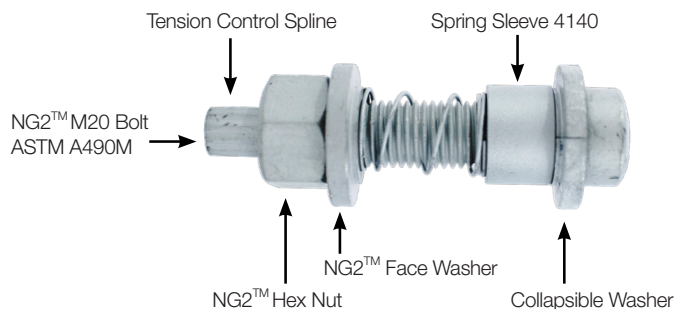

High tension coil spring insures shear sleeve is engaged into the shear zone in the slip critical connection.

The spring does not contribute to the structural integrity of the bolt. Its purpose is to hold the shear sleeve in correct position.

TYPICAL NG2™ BOLT DETAIL

Pre-Tension



Post-Tension





NEXGEN2™ ONESIDE® BOLT

MATERIAL SPECIFICATIONS & TESTING

TYPICAL NG2™ BOLT DETAIL

TYPICAL NG2™ BOLT DETAIL: *PRE-TENSION*

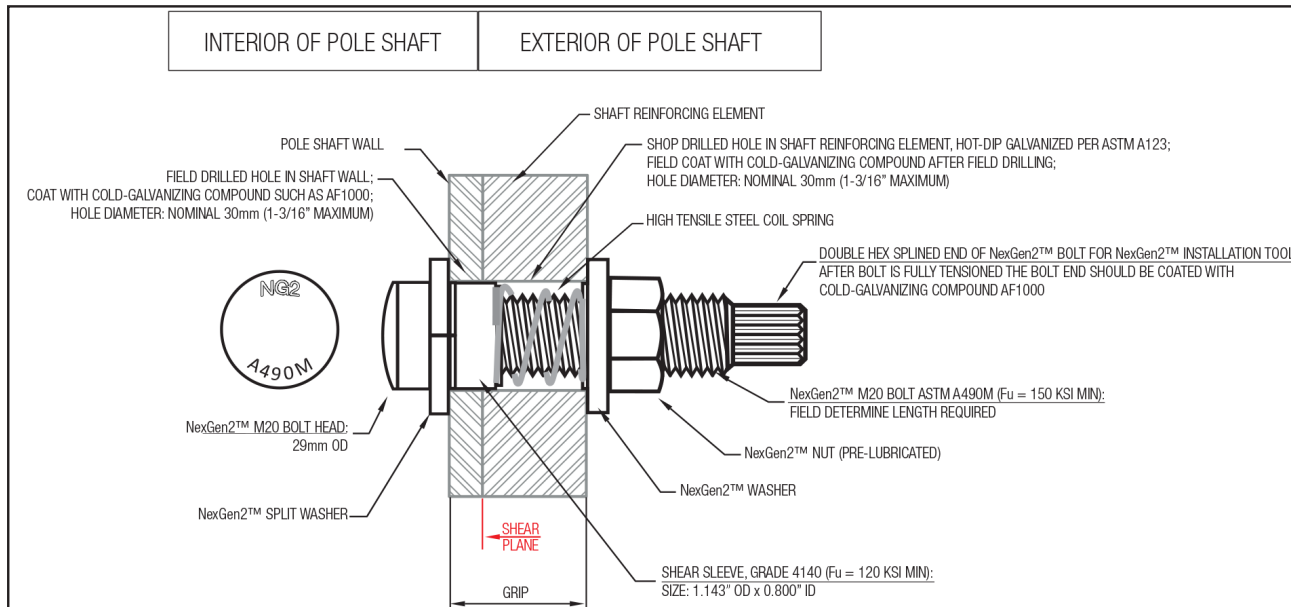

TYPICAL NG2™ BOLT DETAIL: *POST-TENSION*

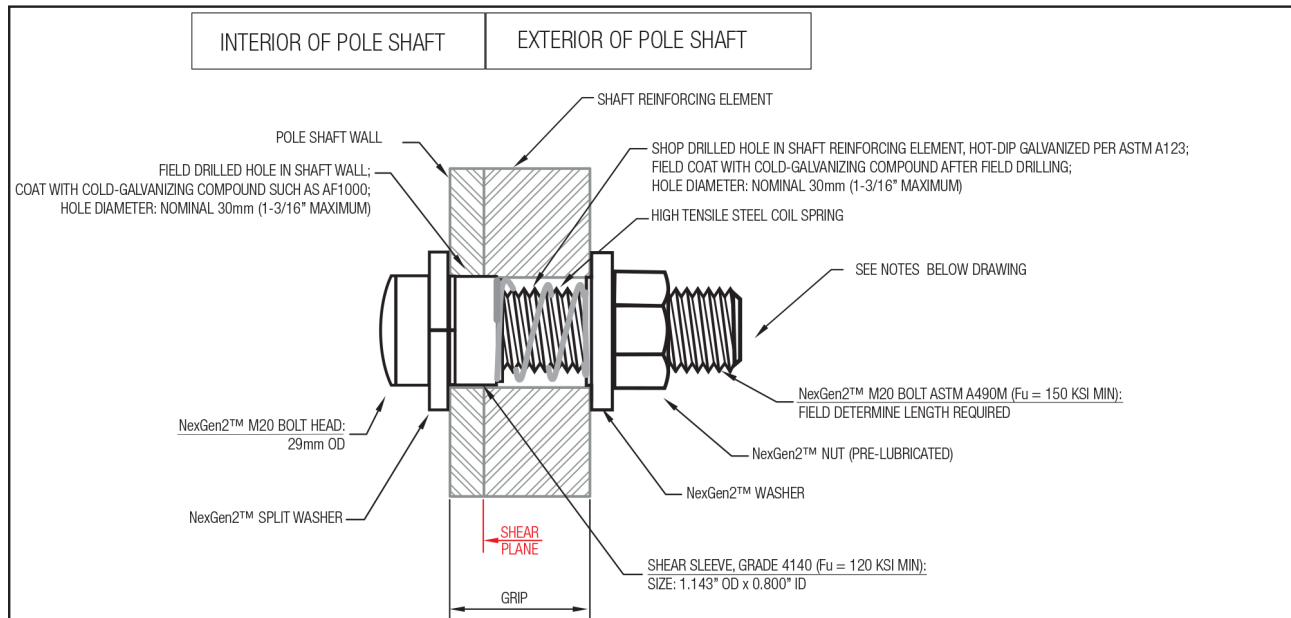



NEXGEN2™ ONESIDE® BOLT

MATERIAL SPECIFICATIONS & TESTING

BOLT TENSIONING TEST

Pretension Skimore Test



Minimum of 28 kips required per manufacturer specifications

TEST REPORTS - MTR



Product Certificate of Conformance

AF Lot #: **9861**

Customer PO #:

Part #: **2NG2036**

Lot Number	Component Part Number	Description	Test Results								
			Proof Load (Mpa)		Hardness (HRC)				Wedge Tensile Test (psi)		
			Spec		Spec		Sample		Spec		Sample
			Min	Sample	Min	Max	A	B	Min	A	B
26308	2NG20095A490M	M20 x 95 NexGen2™ Structural Bolt			33	38	Pass	Pass	150000	Pass	Pass
41002	2HHNM2025G2HM	M20-2.50 Heavy Hex Nut Grade 2H	1165	Pass	24	36	Pass	Pass			
794351	14SLSS1116M	11/16" Shear Sleeve			24	33	Pass	Pass			
54179	2NG2SWH	M20 NexGen2™ Collapsible Split Washer			23	34	Pass	Pass			
51974	2NG2CWM	M20 Solid Collar Washer			23	34	Pass	Pass			



NEXGEN2™ ONESIDE® BOLT

MATERIAL SPECIFICATIONS & TESTING

TEST REPORTS



A DIVISION OF J.T. ADAMS CO., INC.

4520 WILLOW PARKWAY
CLEVELAND, OHIO 44125
PHONE (216) 641-3290
FAX (216) 641-1223
www.tensile.com

CERTIFIED TEST REPORT

Allfasteners
15401 Commerce Park Drive
Cleveland OH 44142

Amended Copy: 1-23-18
Job No.: 1503-20-1173
Date: 3-20-15
Cust. PO#: 41875

Description: 6 samples M20 x 2.5 Order Code: 00-7760-00 Bolts

Spec: ASTM A490M-14a

TEST RESULTS

ID#	Axial Tensile, lbs
Requirements (Min.):	56,900-65,636
1	62,000
2	62,000
3	62,000

Test Method: ASTM F606-14

ID#	Single Shear, lbs
1	76,500
2	80,500
3	77,500

Test Method: ASTM F606-14, NASM 1312-20 (11)

Authorized Agent





NEXGEN2™ ONESIDE® BOLT

MATERIAL SPECIFICATIONS & TESTING

A490M TEST REPORT

ID#
Requirements (Min.):

Axial Tensile, lbs
56,900-65,636



62,000



62,000



62,000

Test Method: ASTM F606-11a

ID#

Single Shear, lbs

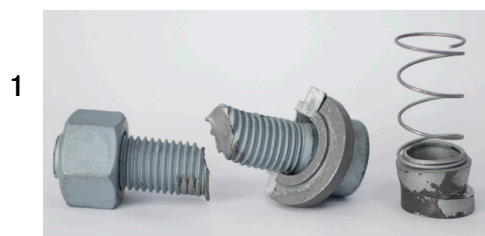

76,500



80,500

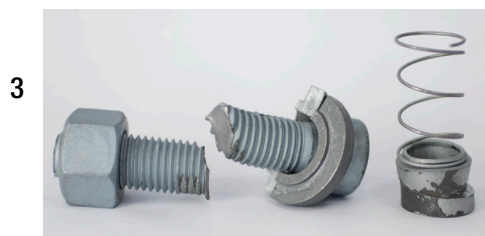

77,500

Test Method: NASM 1312-20 (11)



NEXGEN2™ ONESIDE® BOLT

MATERIAL SPECIFICATIONS & TESTING

SHEAR & TENSILE STRENGTH

Properties:

NexGen2™ M20 Bolt:

Material Grade:	ASTM A490M
Nominal Bolt Diameter, d_b :	0.787 in
Nominal Bolt Area, A_{bolt} :	0.487 in ²
Net Bolt Area, A_n :	0.379 in ²

Shear Sleeve:

Material Grade:	ASTM A519 Grade 4140 ($F_u=120$ ksi min.)
Outside Diameter:	1.143 in
Inside Diameter:	0.800 in
Shear Sleeve Area, A_s :	0.523 in ²

Allowable Strengths in accordance with ANSI/TIA/EIA-222-F:

Note: All values below do not include the 4/3 increase allowed for transient load combinations

Allowable Tensile Strength:

$$R_{at} = F_t A_b$$

$$F_t = 54 \text{ ksi} \quad (\text{Table J3.2})$$

$$A_{bolt} = 0.487 \text{ in}^2$$

$$R_{at} = (54)(0.487) = 26.3 \text{ kips}$$

26.3 kips – Tensile Capacity

Allowable Shear Strength – Threads Included ('N'):

$$R_{av} = F_v A_b$$

$$F_{v_bolt} = 28 \text{ ksi} \quad (\text{Table J3.2})$$

$$F_{v_sleeve} = 30 \text{ ksi} \quad (\text{Table J3.2})$$

$$A_{bolt} = 0.487 \text{ in}^2$$

$$A_s = 0.523 \text{ in}^2$$

$$R_{av} = (28)(0.487) + (30)(0.523) = 29.3 \text{ kips}$$

29.3 kips – 'N' Shear Capacity

Allowable Shear Strength – Threads Excluded ('X'):

$$R_{av} = F_v A_b$$

$$F_{v_bolt} = 40 \text{ ksi}$$

$$F_{v_sleeve} = 30 \text{ ksi} \quad (\text{Table J3.2})$$

$$A_{bolt} = 0.487 \text{ in}^2$$

$$A_s = 0.523 \text{ in}^2$$

$$R_{av} = (40)(0.487) + (30)(0.523) = 35.2 \text{ kips}$$

35.2 kips – 'X' Shear Capacity

Design Strengths in accordance with ANSI/TIA-222-G:

Design Tensile Strength:

$$\phi R_{nt} = \phi F_{ub} A_n \quad (\text{Section 4.9.6.1})$$

$$\phi = 0.75$$

$$F_{ub} = 150 \text{ ksi}$$

$$A_n = 0.379 \text{ in}^2$$

$$\phi R_{nt} = (0.75)(150)(0.379) = 42.6 \text{ kips}$$

42.6 kips – Tensile Capacity

Design Shear Strength – Threads Included ('N'):

$$\phi R_n = \phi 0.45 F_{ub} A_b \quad (\text{Section 4.9.6.3})$$

$$\phi = 0.75$$

$$F_{ub} = 150 \text{ ksi}$$

$$F_{us} = 120 \text{ ksi}$$

$$A_{bolt} = 0.487 \text{ in}^2$$

$$A_s = 0.523 \text{ in}^2$$

$$\phi R_n = (0.75)(150*0.45*0.487 + 120*0.55*0.523) = 50.5 \text{ kips}$$

50.5 kips – 'N' Shear Capacity

Design Shear Strength – Threads Excluded ('X'):

$$\phi R_n = \phi 0.55 F_{ub} A_b \quad (\text{Section 4.9.6.3})$$

$$\phi = 0.75$$

$$F_{ub} = 150 \text{ ksi}$$

$$F_{us} = 120 \text{ ksi}$$

$$A_{bolt} = 0.487 \text{ in}^2$$

$$A_s = 0.523 \text{ in}^2$$

$$\phi R_n = (0.75)(150*0.55*0.487 + 120*0.55*0.523) = 56.0 \text{ kips}$$

56.0 kips – 'X' Shear Capacity

**SHEAR & TENSILE STRENGTH (CONT'D)****Design Strengths in accordance with ANSI/TIA-222-H:****Design Tensile Strength:**

$$\phi R_{nt} = \phi F_{ub} A_n \quad (\text{Section 4.9.6.1})$$

$$\phi = 0.75$$

$$F_{ub} = 150 \text{ ksi}$$

$$A_n = 0.379 \text{ in}^2$$

$$\phi R_{nt} = (0.75)(150)(0.379) = 42.6 \text{ kips}$$

42.6 kips – Tensile Capacity**Design Shear Strength – Threads Included ('N'):**

$$\phi R_n = \phi 0.45 F_{ub} A_b \quad (\text{Section 4.9.6.3})$$

$$\phi = 0.75$$

$$F_{ub} = 150 \text{ ksi}$$

$$F_{us} = 120 \text{ ksi}$$

$$A_{bolt} = 0.487 \text{ in}^2$$

$$A_s = 0.523 \text{ in}^2$$

$$\phi R_n = (0.75)(150*0.45*0.487+120*0.563*0.523) = 51.2 \text{ kips}$$

51.2 kips – 'N' Shear Capacity**Design Shear Strength – Threads Excluded ('X'):**

$$\phi R_n = \phi 0.563 F_{ub} A_b \quad (\text{Section 4.9.6.3})$$

$$\phi = 0.75$$

$$F_{ub} = 150 \text{ ksi}$$

$$F_{us} = 120 \text{ ksi}$$

$$A_{bolt} = 0.487 \text{ in}^2$$

$$A_s = 0.523 \text{ in}^2$$

$$\phi R_n = (0.75)(150*0.563*0.487+120*0.563*0.523) = 57.3 \text{ kips}$$

57.3 kips – 'X' Shear Capacity**Design Strengths in accordance with AISC 360-05 (13th Edition):****Design Tensile Strength:**

$$\phi R_n = \phi F_n A_b \quad (\text{Equation: J3-1})$$

$$\phi = 0.75$$

$$F_n = 113 \text{ ksi} \quad (\text{Table J3.2})$$

$$A_b = A_{bolt} = 0.487 \text{ in}^2$$

$$\phi R_n = (0.75)(113)(0.487) = 41.3 \text{ kips}$$

41.3 kips – Tensile Capacity**Design Shear Strength – Threads Included ('N'):**

$$\phi R_n = \phi F_n A_b \quad (\text{Equation: J3-1})$$

$$\phi = 0.75$$

$$F_{n_bolt} = 60 \text{ ksi} \quad (\text{Table J3.2})$$

$$F_{n_sleeve} = 60 \text{ ksi} \quad (\text{Table J3.2})$$

$$A_{bolt} = 0.487 \text{ in}^2$$

$$A_s = 0.523 \text{ in}^2$$

$$\phi R_n = (0.75)(0.487*60+0.523*60) = 45.5 \text{ kips}$$

45.5 kips – 'N' Shear Capacity**Design Shear Strength – Threads Excluded ('X'):**

$$\phi R_n = \phi F_n A_b \quad (\text{Equation: J3-1})$$

$$\phi = 0.75$$

$$F_{n_bolt} = 75 \text{ ksi} \quad (\text{Table J3.2})$$

$$F_{n_sleeve} = 60 \text{ ksi} \quad (\text{Table J3.2})$$

$$A_{bolt} = 0.487 \text{ in}^2$$

$$A_s = 0.523 \text{ in}^2$$

$$\phi R_n = (0.75)(75*0.487+60*0.523) = 50.9 \text{ kips}$$

50.9 kips – 'X' Shear Capacity



NEXGEN2™ ONESIDE® BOLT
MATERIAL SPECIFICATIONS & TESTING

SHEAR & TENSILE STRENGTH (CONT'D)

Design Strengths in accordance with AISC 360-10 (14th Edition):

Design Tensile Strength:

$\phi R_n = \phi F_n A_b$ (Equation: J3-1)

$\phi = 0.75$

$F_n = 113 \text{ ksi}$ (Table J3.2)

$A_b = A_{bolt} = 0.487 \text{ in}^2$

$\phi R_n = (0.75)(113)(0.487) = 41.3 \text{ kips}$

41.3 kips – Tensile Capacity

Design Shear Strength – Threads Included ('N'):

$\phi R_n = \phi F_n A_b$ (Equation: J3-1)

$\phi = 0.75$

$F_{n_bolt} = 68 \text{ ksi}$ (Table J3.2)

$F_{n_sleeve} = 68 \text{ ksi}$ (Table J3.2)

$A_{bolt} = 0.487 \text{ in}^2$

$A_s = 0.523 \text{ in}^2$

$\phi R_n = (0.75)(68*0.487+68*0.523) = 51.5 \text{ kips}$

51.5 kips – 'N' Shear Capacity

Design Shear Strength – Threads Excluded ('X'):

$\phi R_n = \phi F_n A_b$ (Equation: J3-1)

$\phi = 0.75$

$F_{n_bolt} = 84 \text{ ksi}$ (Table J3.2)

$F_{n_sleeve} = 68 \text{ ksi}$ (Table J3.2)

$A_{bolt} = 0.487 \text{ in}^2$

$A_s = 0.523 \text{ in}^2$

$\phi R_n = (0.75)(84*0.487+68*0.523) = 57.4 \text{ kips}$

57.4 kips – 'X' Shear Capacity

NG2™ LRFD SHEAR DESIGN STRENGTH BASED ON THE EXTERIOR PLY

LRFD Bolt Shear Design Strength (kips)

ASTM A53-35	ASTM A36	ASTM A572-42	ASTM A572-50	ASTM A572-55	ASTM A572-60	ASTM A527-65
38.6	37.3	38.6	40.6	40.6	40.6	40.6

For SI: 1 kip = 4.448 kN

1. LRFD Design Strength based in resistance factor $\phi = 0.55$. For ASD Allowable Strength, divide tabulated values by 0.55 and then divide by safety factor $\Omega = 2.91$.
2. The shear sleeve must extend into the shear plane a minimum of 0.3125 in. (7.9 mm).
3. The exterior ply thickness must not be less than 0.500 in. (12.7 mm). The interior ply thickness must not be less than 0.1875 in. (4.8 mm).
4. The exterior and interior ply material tensile strength (F_u) must not be less than 58ksi (400 MPA).
5. The distance between centers of the bolt holes must be less than 3.0 in. (76 mm). The distance between the centers of the bolt hole and the end of the steel elements to be connected must not be less than 1.5 in. (38 mm).
6. These design strengths represent the minimum individual bolt capacity for a bolt location within an end connection.

**NEXGEN2™ ONESIDE® BOLT**
MATERIAL SPECIFICATIONS & TESTING**NG2™ LRFD SHEAR DESIGN STRENGTH BASED ON THE INTERIOR PLY**

LRFD Bolt Shear Design Strength (kips)

Interior Ply Thickness, t (in.)	Interior Ply Material Grade						
	ASTM A53-35	ASTM A36	ASTM A572-42	ASTM A572-50	ASTM A572-55	ASTM A572-60	ASTM A572-65
0.1875 (3/16)	18.4	17.7	18.4	19.9	21.4	22.9	24.5
0.2188 (7/32)	21.4	20.7	21.4	23.2	25.0	26.8	28.5
0.2500 (1/4)	24.5	23.7	24.5	26.5	28.5	30.6	32.6
0.2813 (9/32)	27.5	26.6	27.5	29.8	32.1	34.4	36.7
0.3125 (5/16)	30.6	29.6	30.6	33.1	35.7	38.2	40.6
0.3438 (11/32)	33.6	32.5	33.6	36.4	39.3	40.6	40.6
0.3750 (3/8)	36.7	35.5	36.7	39.8	40.6	40.6	40.6
0.4063 (13/32)	39.8	38.4	39.8	40.6	40.6	40.6	40.6
0.4375 (7/16)	40.6	40.6	40.6	40.6	40.6	40.6	40.6
0.4688 (15/32)	40.6	40.6	40.6	40.6	40.6	40.6	40.6
≥ 0.5000 (1/2)	40.6	40.6	40.6	40.6	40.6	40.6	40.6

For SI: 1 inch = 25.4 mm; 1 kip = 4.448kN

1. LRFD Design Strength based in resistance factor $\phi = 0.55$. For ASD Allowable Strength, divide tabulated values by 0.55 and then divide by safety factor $\Omega = 2.91$.
2. The shear sleeve must extend into the shear plane a minimum of 0.3125 in. (7.9 mm).
3. The exterior ply thickness must not be less than 0.500 in. (12.7 mm). The interior ply thickness must not be less than 0.1875 in. (4.8 mm).
4. The exterior and interior ply material tensile strength (F_u) must not be less than 58ksi (400 MPA).
5. The distance between centers of the bolt holes must be less than 3.0 in. (76 mm). The distance between the centers of the bolt hole and the end of the steel elements to be connected must not be less than 1.5 in. (38 mm).
6. These design strengths represent the minimum individual bolt capacity for a bolt location within an end connection.



NEXGEN2™ ONESIDE® BOLT

MATERIAL SPECIFICATIONS & TESTING

NG2™ LRFD SHEAR DESIGN STRENGTH BASED ON THE EXTERIOR & INTERIOR PLIES

LRFD Bolt Shear Design Strength (kips)

Interior Ply Thickness, t (in.)	Ply Material Grade						
	ASTM A53-35	ASTM A36	ASTM A572-42	ASTM A572-50	ASTM A572-55	ASTM A572-60	ASTM A572-65
0.1875 (3/16)	20.5	21.1	24.6	28.6	30.8	31.1	31.1
0.2188 (7/32)	24.0	24.6	28.7	31.1	31.1	31.1	31.1
0.2500 (1/4)	27.4	28.2	31.1	31.1	31.1	31.1	31.1
0.2813 (9/32)	30.8	31.1	31.1	31.1	31.1	31.1	31.1
0.3125 (5/16)	31.1	31.1	31.1	31.1	31.1	31.1	31.1
≥ 0.3750 (3/8)	31.1	31.1	31.1	31.1	31.1	31.1	31.1

For SI: 1 inch = 25.4 mm; 1 kip = 4.448kN

- LRFD Design Strength based in resistance factor $\phi = 0.55$. For ASD Allowable Strength, divide tabulated values by 0.55 and then divide by safety factor $\Omega = 2.91$.
- The shear sleeve must extend into the shear plane a minimum of 0.3125 in. (7.9 mm).
- The exterior ply thickness must not be less than 0.500 in. (12.7 mm). The interior ply thickness must not be less than 0.1875 in. (4.8 mm).
- The exterior and interior ply material tensile strength (F_u) must not be less than 58ksi (400 MPA).
- The distance between centers of the bolt holes must be less than 3.0 in. (76 mm). The distance between the centers of the bolt hole and the end of the steel elements to be connected must not be less than 1.5 in. (38 mm).
- These design strengths represent the minimum individual bolt capacity for a bolt location within an end connection.

TENSION & SHEAR STRENGTH SUMMARY

DESIGN STANDARD		ALLOWABLE STRENGTH (KIPS) W/O 4/3 INCREASE			DESIGN STRENGTH (KIPS)	
		TIA-F	TIA-G	TIA-H	AISC 360-05	AISC 360-10
TENSILE STRENGTH		26.3	42.6	42.6	41.3	41.3
SHEAR STRENGTH	N	29.3	50.5	51.2	45.5	51.5
	X	35.2	56.0	57.3	50.9	57.4
PRETENSION/CLAMP FORCE		32				

Structural calculations prepared by Ryan J. Rimmele, PE, SE and Tower Engineering Professionals

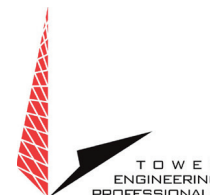



NEXGEN2™ ONESIDE® BOLT

MATERIAL SPECIFICATIONS & TESTING

ACCESSORIES

M20 NexGen2™ Extended Range Shear Wrench	9NG2-22
M20 Outer Socket Extension for NexGen2™ Extended Range Shear Wrench	13NG2-EXT
NexGen2™ Installation Tool	13NG2IT



9NG2-22



13NG2-EXT



13NG2IT

Additional TDS and Information Sheets available for AF Shear Wrench and AF Extended Shear Wrench.

INSTALLATION

Online installation videos, On-site demos and training available for NexGen2™ Oneside Bolt Assembly. Ask a sales representative today.



Scan the QR Code to Watch the NexGen2™ Install Video!

Step-by-step instructions located on next page of NexGen2™ TDS



NEXGEN2™ ONESIDE® BOLT

MATERIAL SPECIFICATIONS & TESTING

INSTALLATION (CONT'D)

PRE-INSTALL BOLT ON INSTALL TOOL:



1 Thread the installation tool tip into the splined end of the bolt.



2 Remove the nut, the face washer and the spring shear sleeve and slide along the handle of the tool.



3 Move the collapsible washer to the correct location on the tool and fold in place.

INSTALLATION:



1 Install the bolt into the hole followed by the collapsible washer.

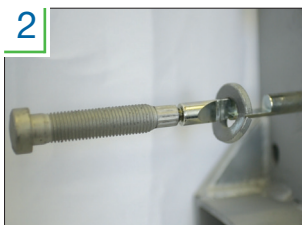

2 Rotate the tool 180°.



3 Pulling back, rock the tool side-to-side to engage the collapsible washer.



4 Engage the spring shear sleeve into the shear plane.

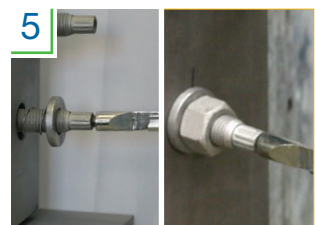

5 Slide the face washer forward and move the nut up to fasten to the bolt. Tighten the nut snug tight at this point.



6 Remove the tool by unscrewing it from bolt (counterclockwise).

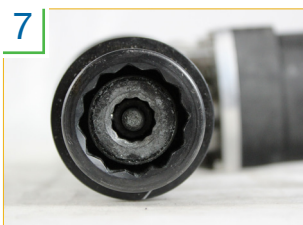

7 Using the shear wrench engage the outer socket with the splined end of the bolt. Press the trigger until correct tension has been achieved (the bolt spline separates from the bolt).





8 Press the small trigger on the shear wrench to eject the bolt spline. The application is now complete.



NEXGEN2™ ONESIDE® BOLT

MATERIAL SPECIFICATIONS & TESTING

ORDERING INFORMATION

Part No.	Bolt Length (mm)	Grip Range	Sleeve Length (in)		
2NG2060	M20 x 60	0.625 min.	N/A	24	1440
2NG2032	M20 x 75	0.625 - 1.375	0.5	24	1440
2NG2036	M20 x 95	0.9375 - 1.4375	0.6875	24	1440
2NG2048	M20 x 95	1.4375 - 1.875	1.1875	24	1440
2NG2057	M20 x 95	1.875 - 2.125	1.625	24	1440
2NG2068	M20 x 135	2.125 - 2.6875	1.75	24	1440
2NG2096	M20 x 135	2.6875 - 3.75	2.4375	24	1440
2NG2127	M20 x 175	3.75 - 5.125	3.47	16	1440
2NG2212	M20 x 250	5 - 8.3125	4	10	1440

DISCLAIMER

IMPORTANT: Information, specifications, procedures and recommendations provided (“information”) are based on our experience and we believe this to be accurate. No representation, guarantee or warranty is made as to the accuracy or completeness of the information or that use of the product will avoid losses or damages or give desired results. It is purchaser’s sole responsibility to test and determine the suitability of any product for the intended use. Tests should be repeated if materials or conditions change in any way. No employee, distributor or agent has any right to change these facts and offer a guarantee of performance.

NOTE TO USER: by ordering/receiving product you accept the ALLFASTENERS General Terms and Conditions of Sale applicable in the region. Please request a copy if you have not received these. These Terms and Conditions contain disclaimers of implied warranties (including but not limited to disclaiming warranties of fitness for a particular purpose) and limits of liability.



ESR-3975 LABC AND LARC SUPPLEMENT

1.0 REPORT PURPOSE & SCOPE

The purpose of this evaluation report supplement is to indicate that NexGen2 OneSide Blind Bolts, described in ICC-ES evaluation report ESR 3975, have also been evaluated for compliance with the codes noted below as adopted by the Los Angeles Department of Building and Safety (LADBS)

Applicable Code Editions:

- 2023 City of Los Angeles Building Code (LABC)

2.0 CONCLUSIONS

The NexGen2 OneSide Blind Bolts, described in Sections 2.0 through 7.0 of the evaluation report ESR-3975, comply with LABC Chapter 22 and are subject to the conditions of use described in this supplement.

3.0 CONDITIONS OF USE

The NexGen2 OneSide Blind Bolts described in this evaluation report supplement must comply with all the following conditions:

- All applicable sections in the evaluation report ESR-3975
- The design, installation, conditions, of use and identification of the NexGen2 OneSide Blind Bolts are in accordance with the 2021 International Building Code (IBC) provisions noted in the evaluation report ESR-3975.
- The design, installation and inspection are in accordance with additional requirements of LABC Chapters 16, 17 and 22, as applicable.

This supplement expires concurrently with the evaluation report, Reissued September 2023



ESR-3975 CBC SUPPLEMENT

1.0 REPORT PURPOSE & SCOPE

The purpose of this evaluation report supplement is to indicate that NexGen2 OneSide Blind Bolts described in ICC-ES evaluation report ESR-3975, have also been evaluated for compliance with the codes noted below:

Applicable Code Editions:

- 2022 California Building Code (CBC)

For evaluation of applicable chapters adopted by the California Office of Statewide Health Planning and Development (OSHPD) AKA: California Department of Health Care Access and Information (HCAI) and the Division of the State Architect (DSA), see Sections 2.1.1 and 2.1.2 below.

2.0 CONCLUSIONS

- 2.1 CBC:** The NexGen2 OneSide Blind Bolts, described in Sections 2.0 through 7.0 of the evaluation report ESR-3975, comply with CBC Chapter 22, provided the design and installation are in accordance with the 2021 International Building Code (IBC), provisions noted in the evaluation report, and the additional inspection requirements of the CBC Chapters 16, 17 and 22, as applicable.
- 2.1.1 OSHPD:** The applicable OSHPD Sections and Chapters of the CBC are beyond the scope of this supplement.
- 2.1.2 DSA:** The applicable DSA Sections and Chapters of the CBC are beyond the scope of this supplement.

The supplement expires concurrently with the evaluation report, reissued September 2023.